

ABR(L)

Directional Rotary Clamp Cylinder

Magnetic type

Internal structure

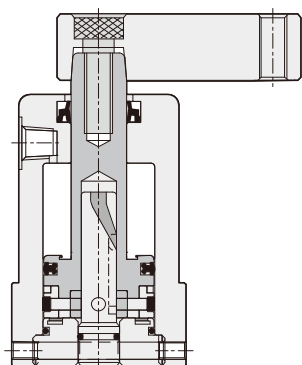

Specification

Item	Bore size (mm)	Ø20	Ø25	Ø32	Ø40	Ø50	Ø63	Ø80
Axis		Ø12	Ø14	Ø16	Ø16	Ø20	Ø20	Ø25
Action		Double acting						
Fluid		Air						
Max. operating pressure	kgf/cm ² (kPa)	10.3 (1030)						
Pressure range	kgf/cm ² (kPa)	1 ~ 7 (100~ 700)						
Rotary stroke	mm	9		11		13		15
Under pressure stroke	mm	13		15		17		20
Body material		Aluminum alloy						
Rotation angle	°	90 ± 2						
Rotation direction		Left (From right to left) - L; Right (From left to right) - R						
Theoretical clamping force	(N)(6 kgf/cm ²)	120	200	360	630	980	1680	2666

Product weight

Stroke size	Ø20	Ø25	Ø32	Ø40	Ø50	Ø63	Ø80
Weight	0.3	0.5	0.7	0.9	1.5	2.1	3.1

Unit: kg

Code of order

AB	R	25	×	13	-	AMS	L	2
Model		Bore size		Stroke		Sensor switch		
<p>L: Left rotation type (from right to left)</p>		20 - Ø20mm 25 - Ø25mm 32 - Ø32mm 40 - Ø40mm 50 - Ø50mm 63 - Ø63mm 80 - Ø80mm		<p>Press stroke (Not include rotation stroke)</p> Ø20 - 13mm Ø25 - 13mm Ø32 - 15mm Ø40 - 15mm Ø50 - 17mm Ø63 - 17mm Ø80 - 17mm		<p>AMS-L 2</p> <p>A M S L</p> <p>M : 2 wire Without contact L : straight cable N : 3 wire Without contact(NPN) V : angle cable(90°) P : 3 wire Without contact(PNP) wire length-L : 2000mm</p> <p>2 : Number of sensor switch 1 = 1 PCS (option) 2 = 2 PCS</p>		
<p>R: Right rotation type (from right to left)</p>								

Dimension

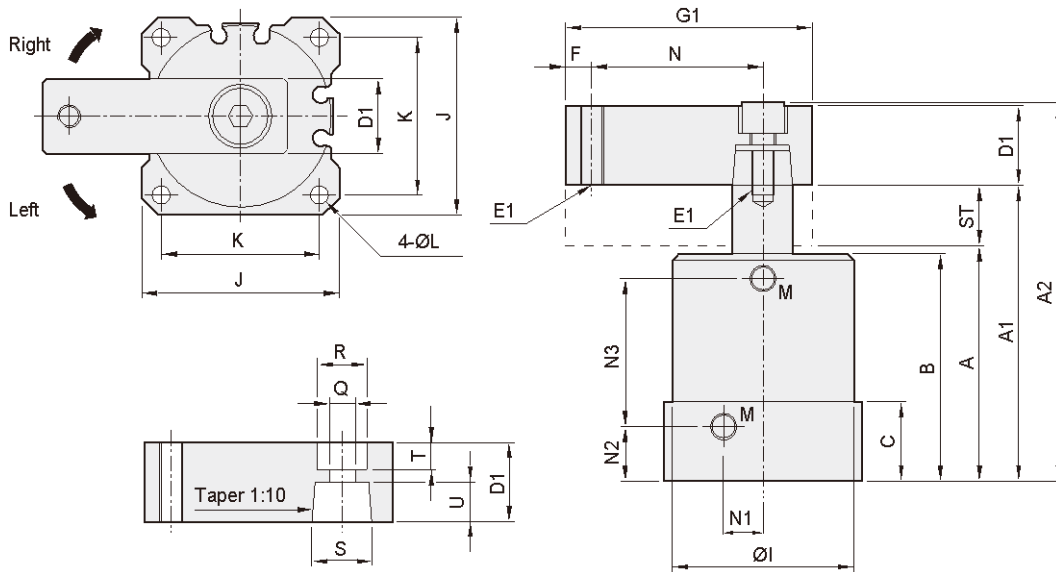

Bore size	ST	A	A1	A2	B	C	D1	E1	F	G1
Ø20	22	67	89	(105.9)	65	23	□ 15.9	M6×1.0	6	50
Ø25	22	67	89	(105.9)	65	23	□ 15.9	M6×1.0	6	50
Ø32	26	82	108	(128)	78	28	□ 19	M8×1.25	8	70
Ø40	26	82	108	(128)	78	28	□ 19	M8×1.25	8	75
Ø50	30	94	124	(150.4)	90	31	□ 25.4	M10×1.5	10	85
Ø63	30	94	124	(150.4)	90	31	□ 25.4	M10×1.5	10	95
Ø80	35	110	145	(176.4)	105	35	□ 30.4	M12×1.75	12.5	127.5

Bore size	I	J	K	L	M	N	Q	R	S	T	U	N1	N2	N3
Ø20	Ø31	33	26	Ø3.3	M5×0.8P	35	Ø6.8	Ø11	Ø12	5	8.5	7.5	13	41.5
Ø25	Ø35	38	30	Ø4.6	M5×0.8P	35	Ø6.8	Ø11	Ø14	5	8.5	8	16.5	39.5
Ø32	Ø46	50	40	Ø5.2	PT 1/8	50	Ø9	Ø14	Ø16	7	9.5	11.5	19	45
Ø40	Ø55	60	48	Ø6.8	PT 1/8	55	Ø9	Ø14	Ø16	7	9.5	14	19	45
Ø50	Ø65	70	57	Ø6.8	PT 1/8	60	Ø11	Ø18	Ø20	9	12.5	17	21	54
Ø63	Ø78	83	67	Ø9	PT 1/8	70	Ø11	Ø18	Ø20	9	12.5	20	21	54
Ø80	Ø96	105	84	Ø11	PT 1/4	90	Ø13	Ø20	Ø25	11	14.5	25.5	23.5	66.5