



ABW Rotary Actuated Air Gripper



Feature

- 90° , 180° rotary and gripping
- Double force rotary
- Wedge bevel structure

Specification

Item	Bore size (mm)	Ø10	Ø16	Ø20	Ø25
Action		Double acting			
Fluid		Air			
Pressure range kgf / cm ² (kPa)	Gripper unit	2 ~ 7 (200 ~ 700)			
	Rotary unit	2 ~ 7 (200 ~ 700)			
Ambient and fluid temperature	°C	5 ~ 60			
Rotation angle	°	90, 180			
Torque force	N·m	0.6	1.5	2.2	3.2
Allowable kinetic energy	J	0.006	0.007	0.025	0.048

Product weight

Bore size	Weight(kg)
Ø10	0.88
Ø16	1.3
Ø20	1.6
Ø25	2.6

Note: All of above are theoretical data.
Weight tolerance about ±5%



Code of order

ABW-10 A-180-AMS-L 2- AMS-L 2

① ② ③ ④ ⑤ ⑥ ⑦

①

Mark	Bore size (mm)
10	Ø10
16	Ø16
20	Ø20
25	Ø25

⑤

Mark	Sensor quantity
1	With 1 sensor switch
2	With 2 sensor switches

②

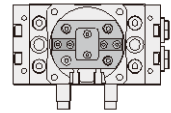
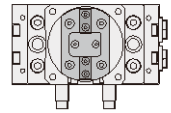
Mark	Starting Position	Description
A		B port face to gripper in horizontal position
B		B port face to gripper in vertical position

⑥

AMS-□

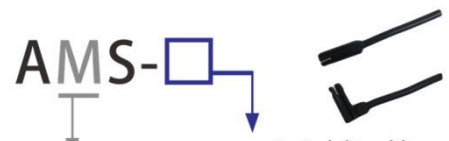

Model : L-straight cable
V-angle cable(90°)

M-2 wire Without contact
N-3 wire Without contact(NPN)
P-3 wire Without contact(PNP)
wire length-L : 2000mm

③

Mark	Rotation angle
90	90°
180	180°

⑦

Mark	Sensor quantity
1	With 1 sensor switch
2	With 2 sensor switches

④

AMS-□

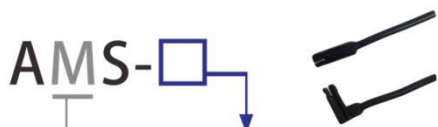

Model : L-straight cable
V-angle cable(90°)

M-2 wire Without contact
N-3 wire Without contact(NPN)
P-3 wire Without contact(PNP)
wire length-L : 2000mm

Rotation range

Starting position at A

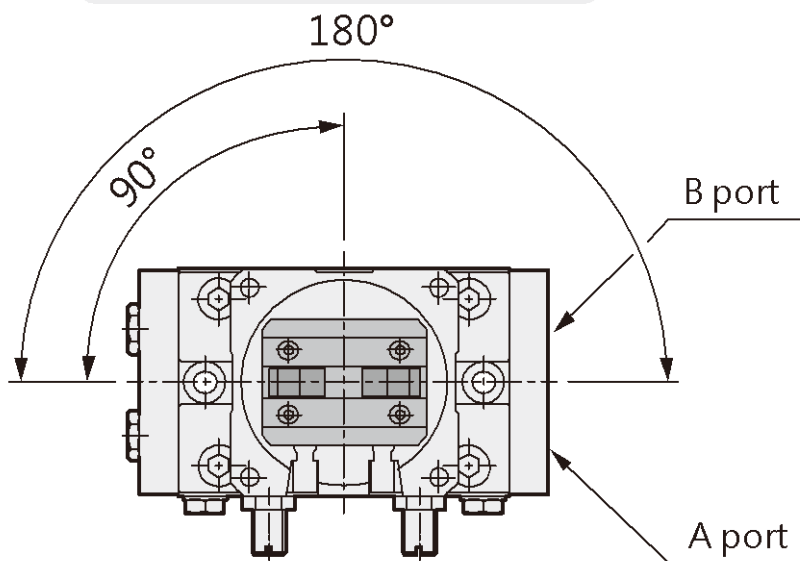

From top view, B port is to activate gripper

Starting position at B

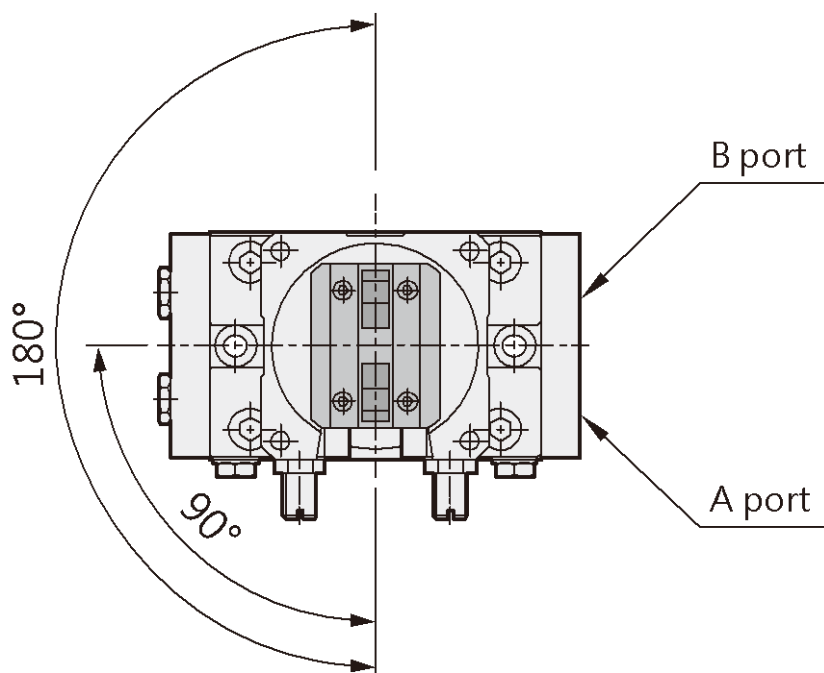

From top view, B port is to activate gripper

Characteristics graph

External grip

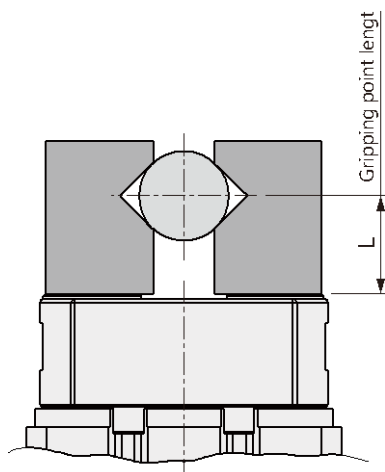

ABW 10

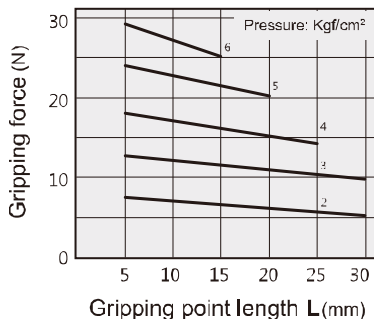

ABW 16

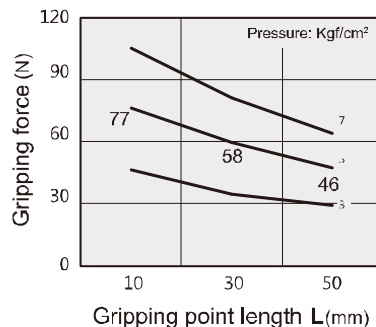

ABW 20

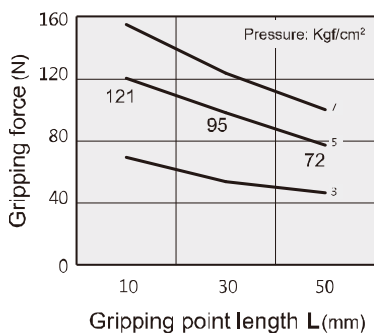

ABW 25

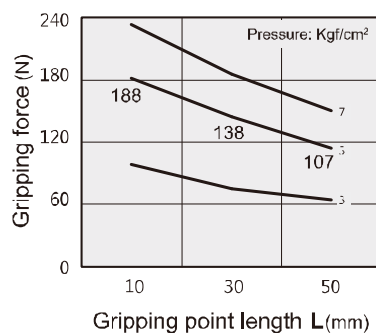

Internal grip

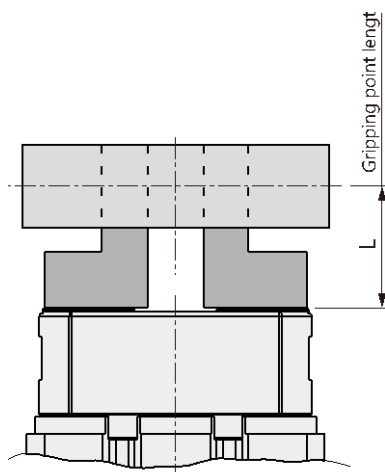

ABW 10

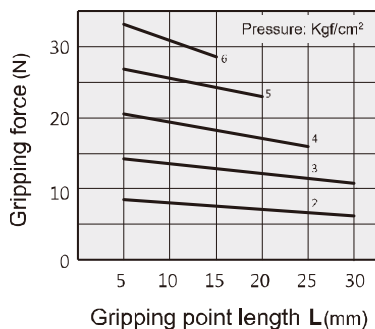

ABW 16

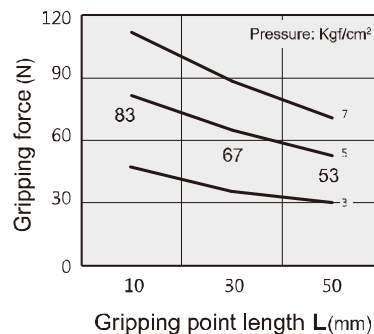

ABW 20

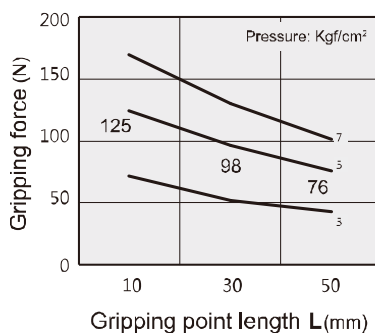

ABW 25

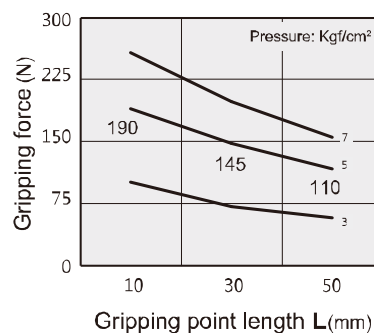

Dimensions

■ ABW-10

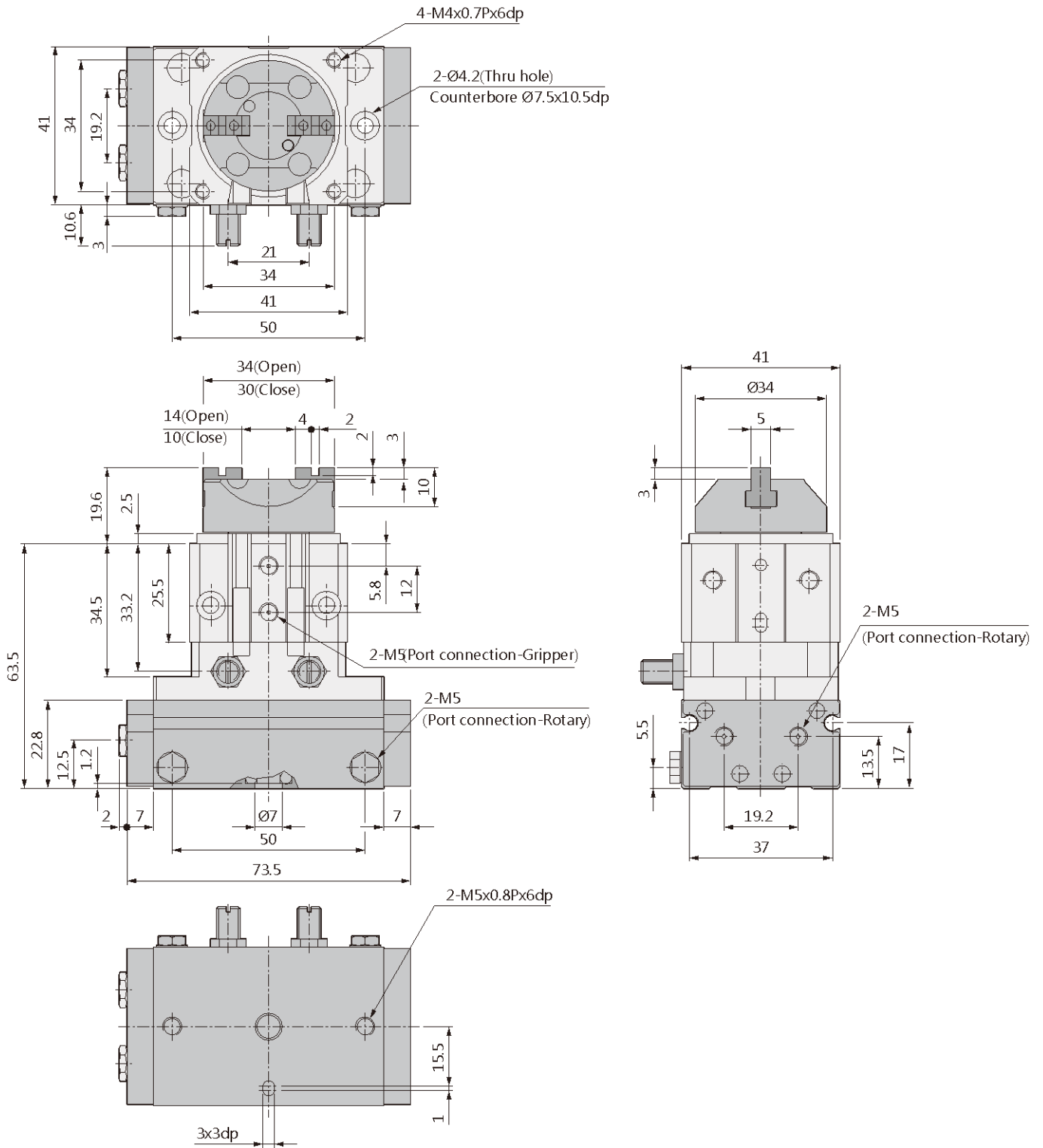

ABW-16

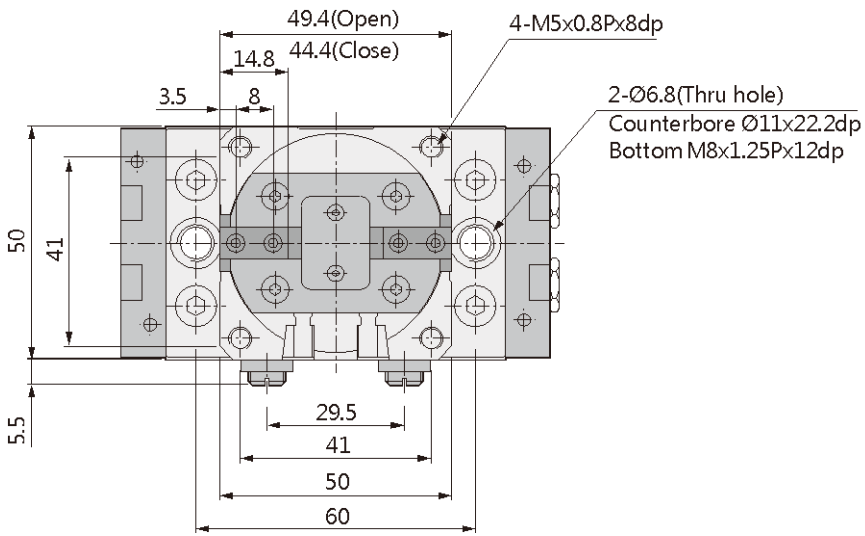

Close-up of centering sleeve

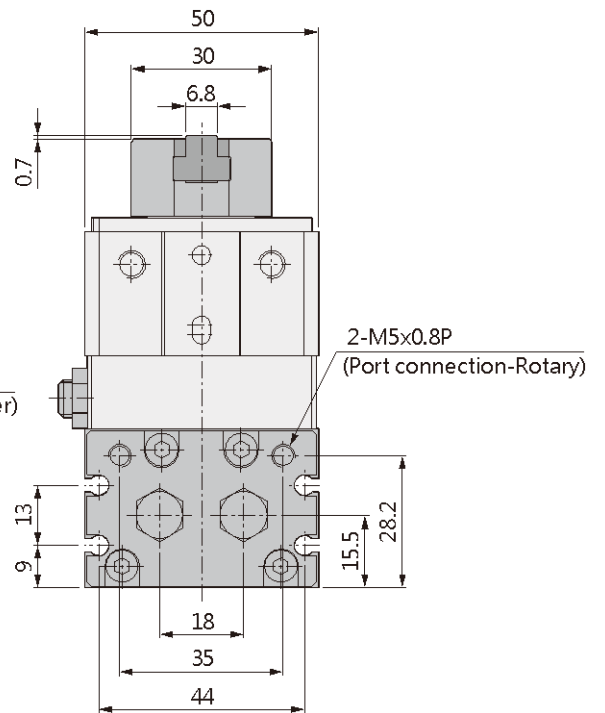
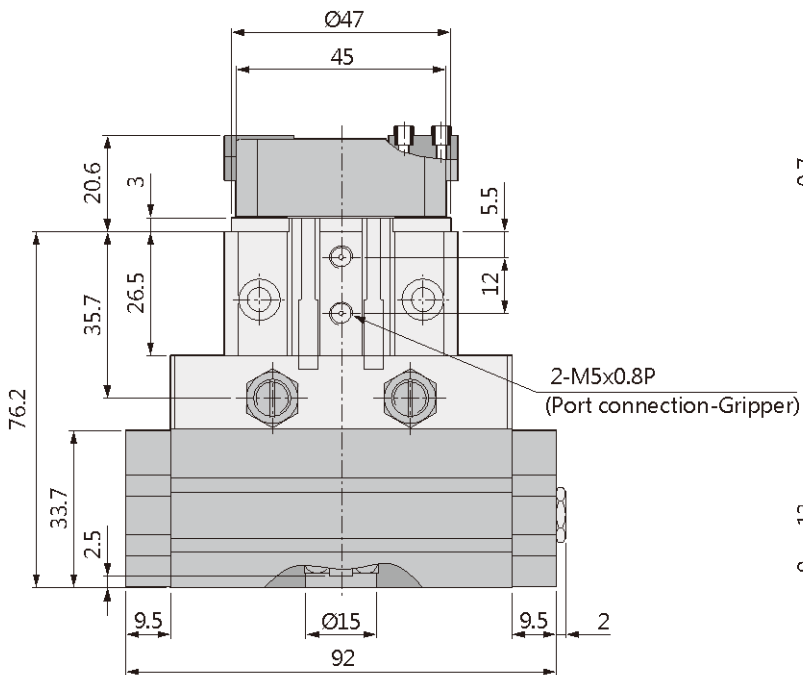
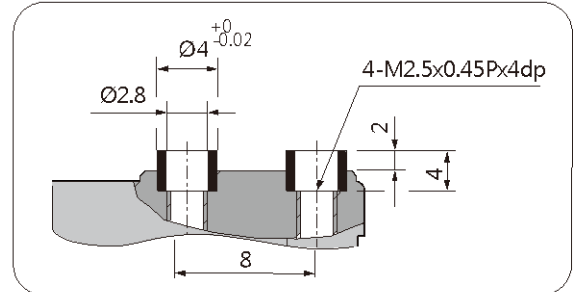

ABW-20

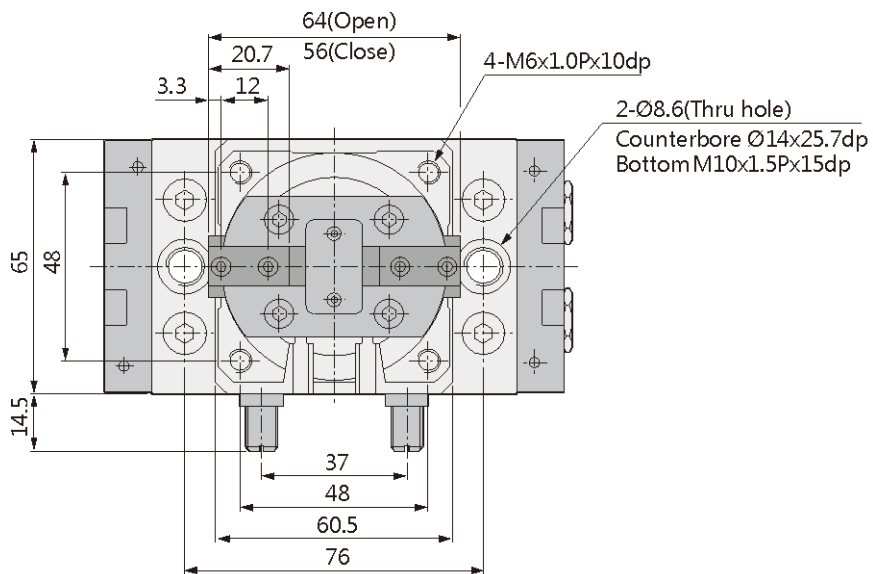

Close-up of centering sleeve

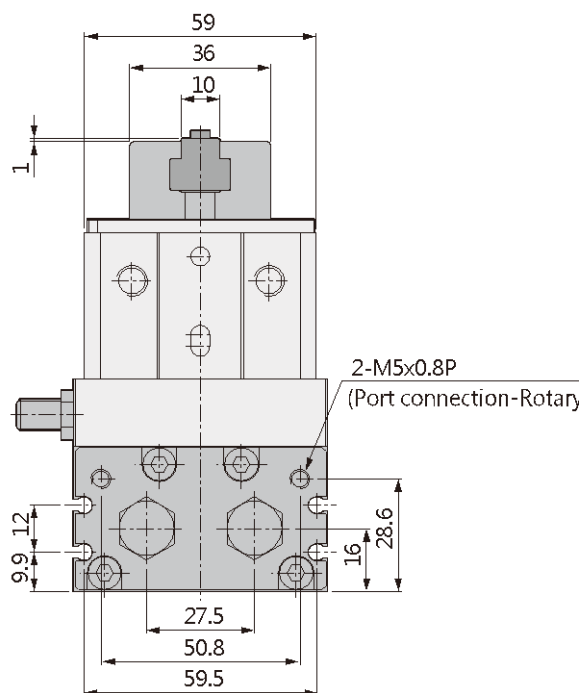
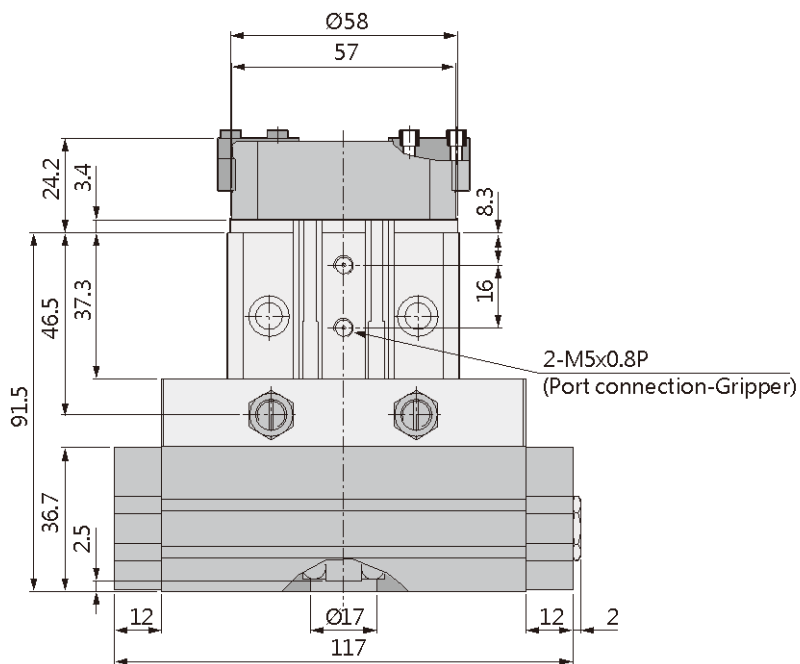
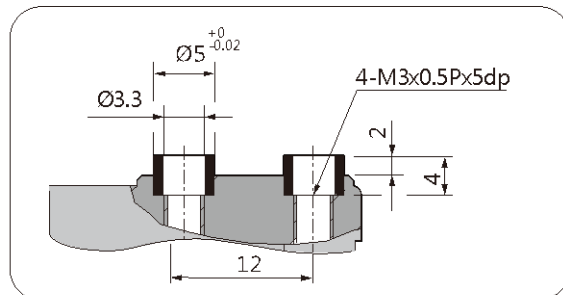

■ ABW-25

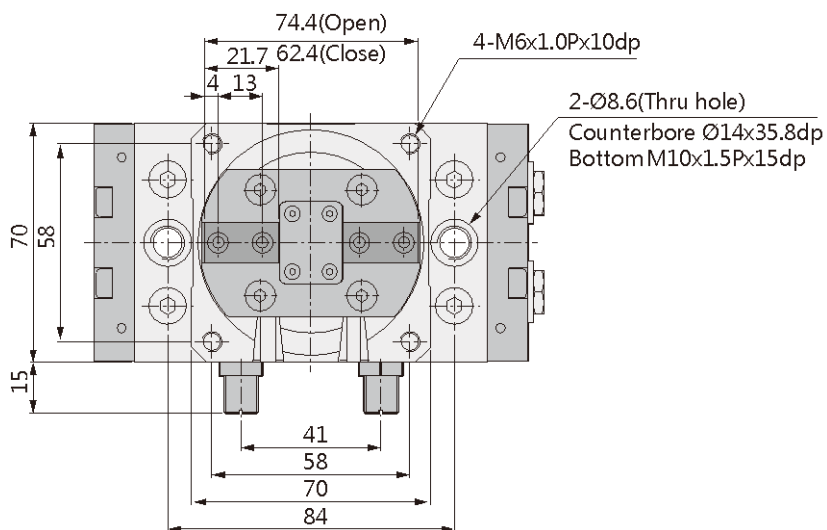

■ Close-up of centering sleeve

