

## ABZ Rotary Actuated Air Gripper

### Feature

- 90° , 180° rotary and gripping
- Double force rotary
- Roller linear guide



### Specification

Item	Bore size (mm)	Ø10	Ø16	Ø20	Ø25
Action		Double acting			
Fluid		Air			
Pressure range kgf / cm <sup>2</sup> (kPa)	Gripper unit	2 ~ 7 ( 200 ~ 700 )			
	Rotary unit	2 ~ 7 ( 200 ~ 700 )			
Ambient and fluid temperature	°C	5 ~ 60			
Rotation angle	°	90, 80			
Torque force	N·m	0.6	1.5	2.2	3.2
Allowable kinetic energy	J	0.006	0.007	0.025	0.048

### Product weight

Bore size	Weight(kg)
Ø10	0.88
Ø16	1.3
Ø20	1.6
Ø25	2.6

Note: All of above are theoretical data.  
Weight tolerance about ±5%



## Code of order

ABZ-10 A-180 AMS-L 2 AMS-L 2

① ② ③ ④ ⑤ ⑥ ⑦

①

Mark	Bore size(mm)
10	Ø10
16	Ø16
20	Ø20
25	Ø25

⑤

Mark	Sensor quantity
1	With 1 sensor switche
2	With 2 sensor switches

②

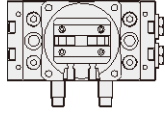
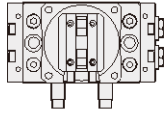
Mark	Starting Position	Description
A		B port face to gripper in horizontal position
B		B port face to gripper in vertical position

⑥

AMS-□ 

Model : L-straight cable  
V-angle cable(90°)

M-2 wire Without contact  
N-3 wire Without contact(NPN)  
P-3 wire Without contact(PNP)  
wire length-L : 2000mm

③

Mark	Rotation angle
90	90°
180	180°

⑦

Mark	Sensor quantity
1	With 1 sensor switch
2	With 2 sensor switches

④

AMS-□ 

Model : L-straight cable  
V-angle cable(90°)

M-2 wire Without contact  
N-3 wire Without contact(NPN)  
P-3 wire Without contact(PNP)  
wire length-L : 2000mm



Rotation range

Starting position at A

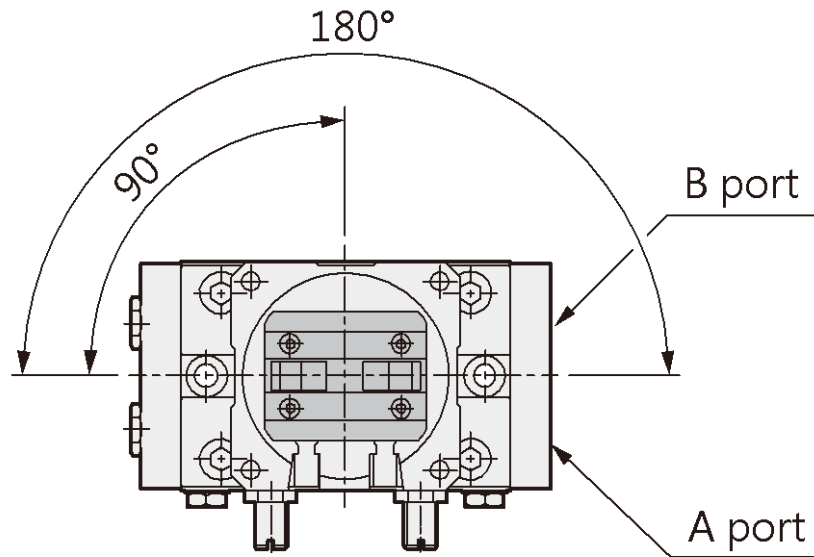

From top view, B port is to activate gripper

Starting position at B

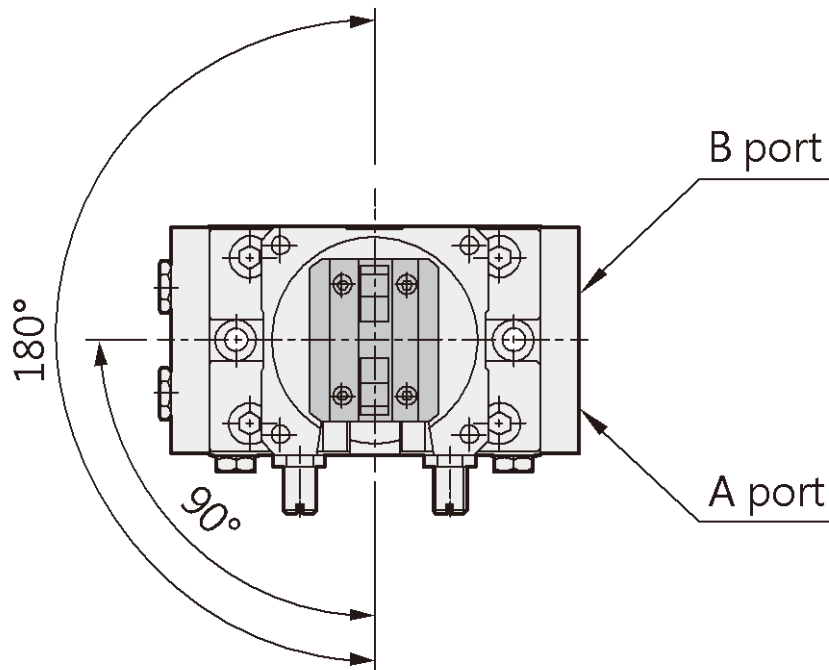

From top view, B port is to activate gripper

## Characteristics graph

### External grip

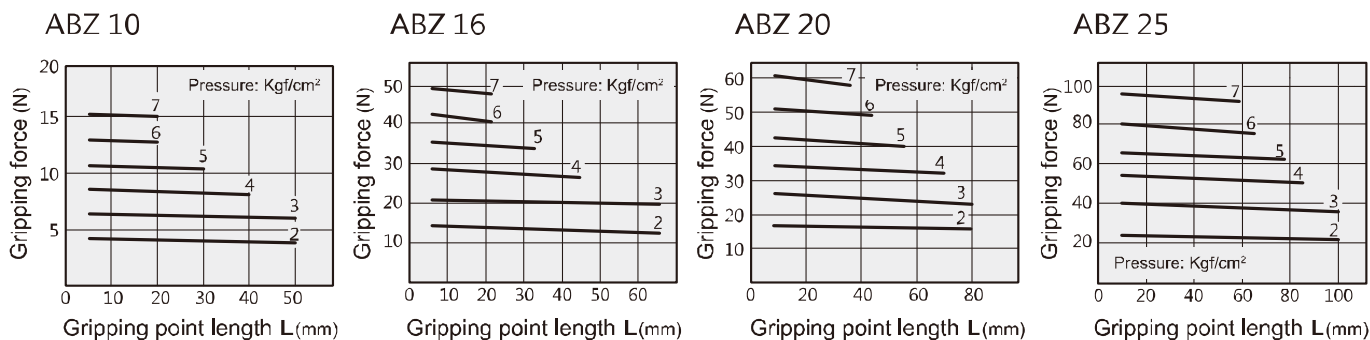
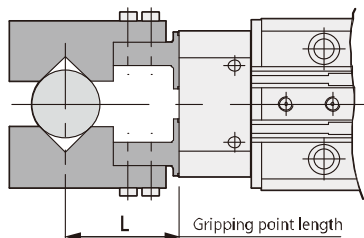

### Internal grip

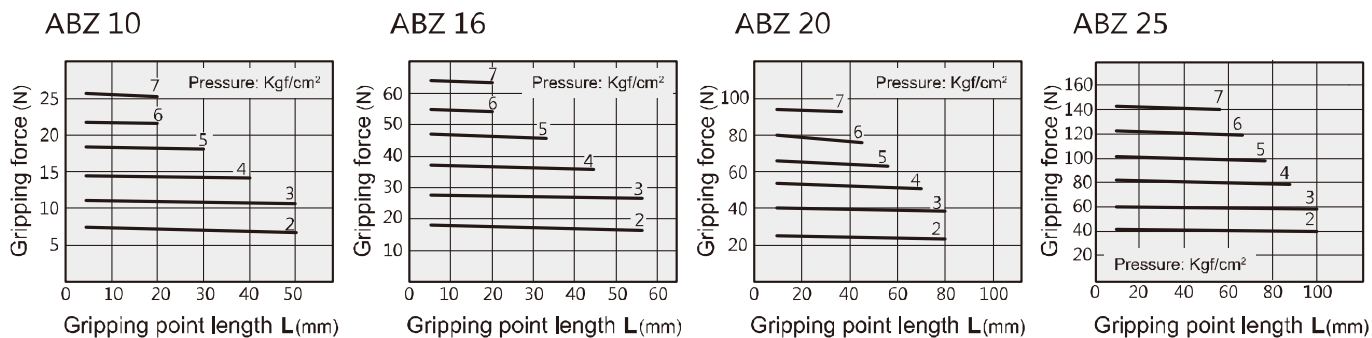
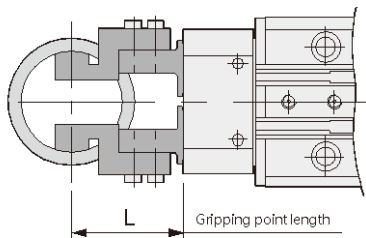



## ■ Gripper maximum allowable displacement - External grip

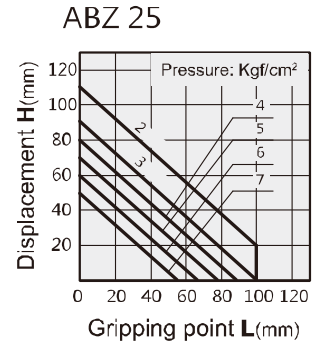
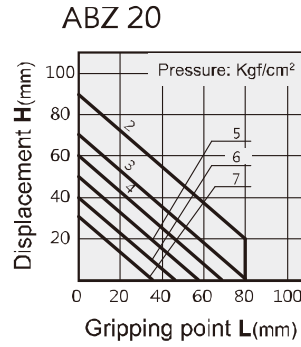
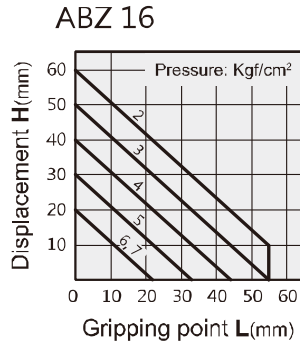
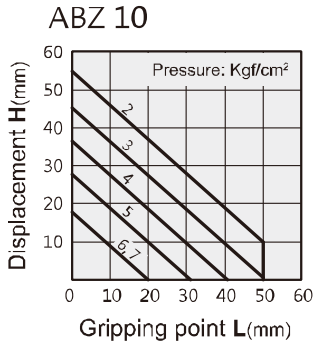
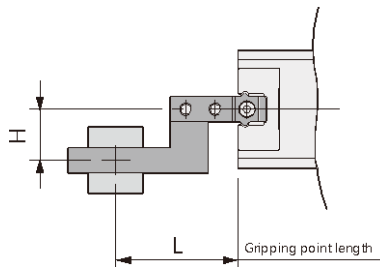

## ■ Gripper maximum allowable displacement - Internal grip

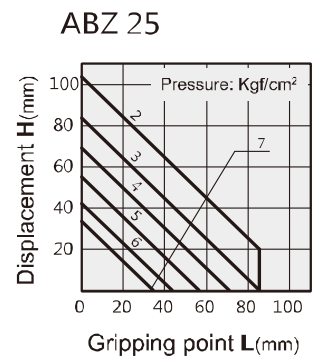
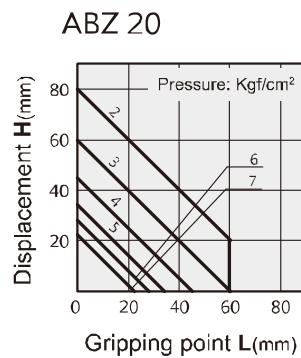
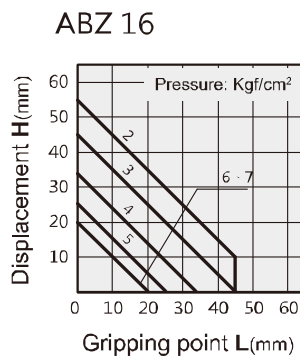
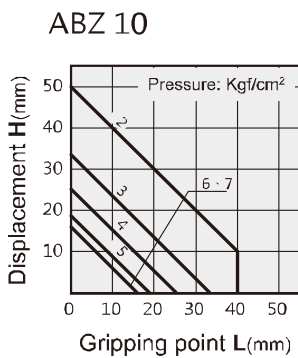
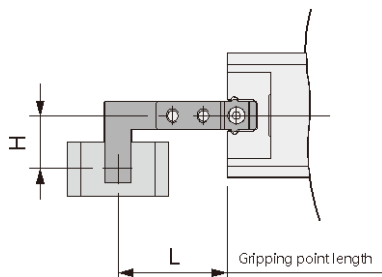

## Dimensions

### ■ ABZ-10

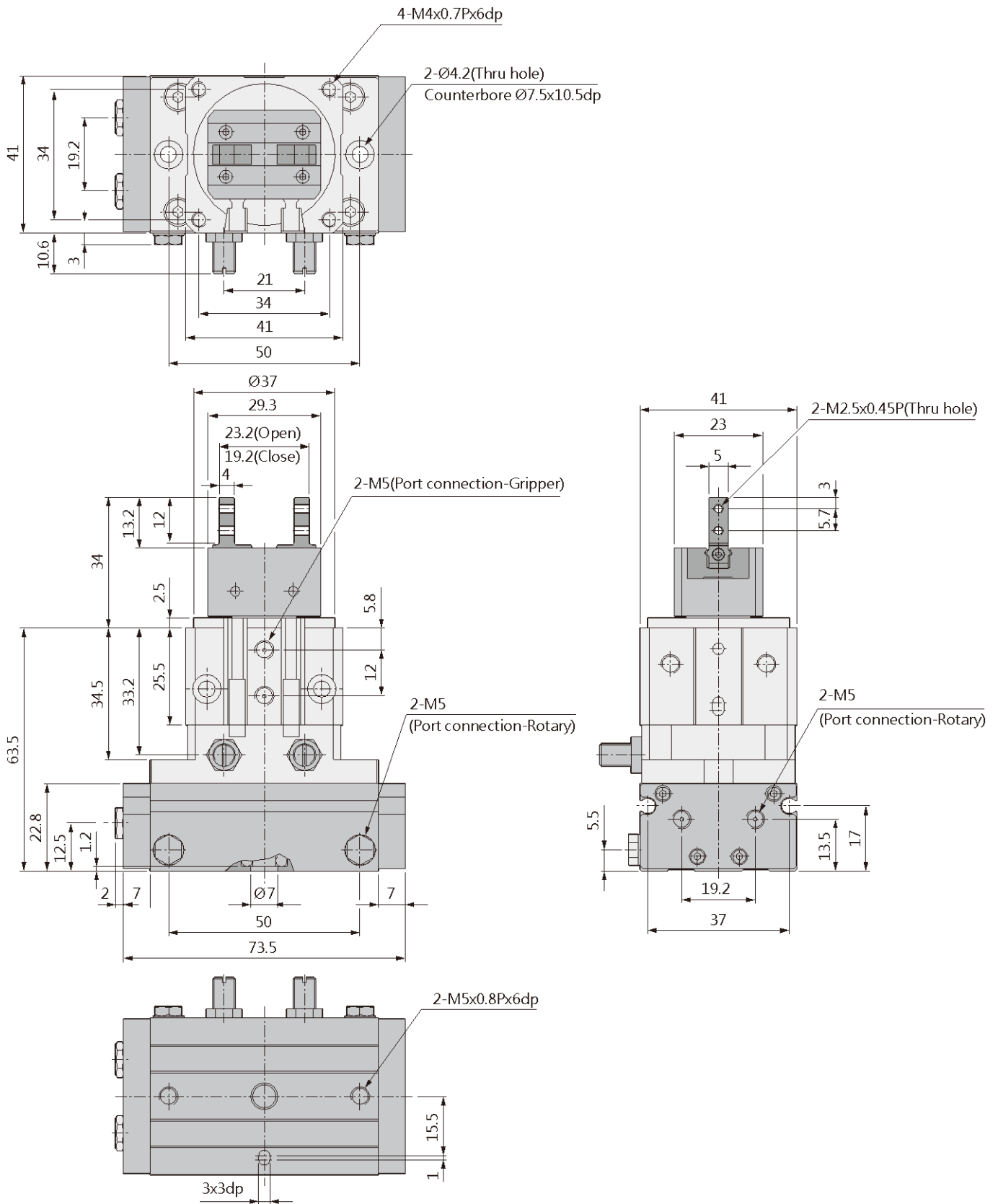



## ■ ABZ-16

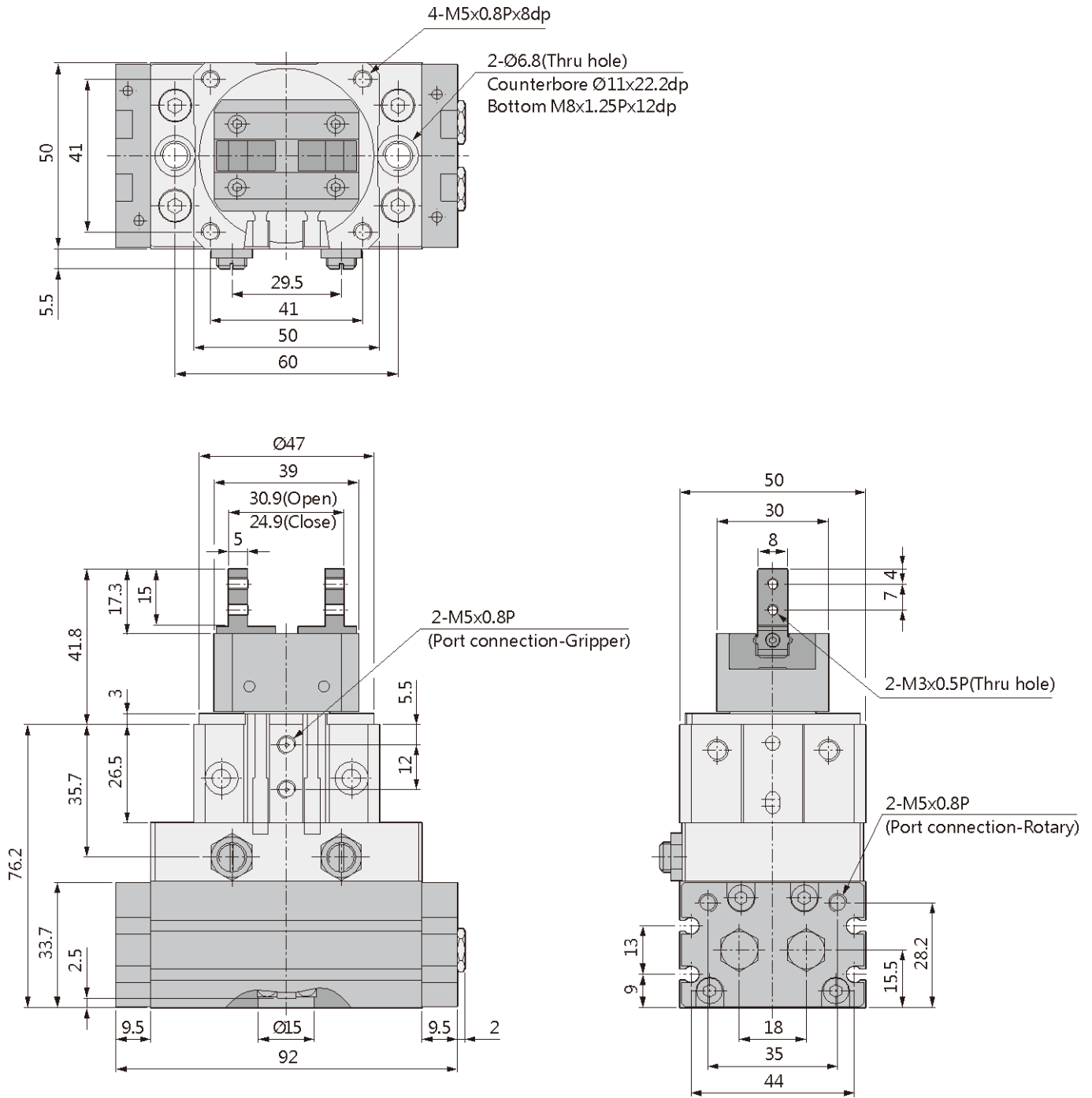



## ■ ABZ-20

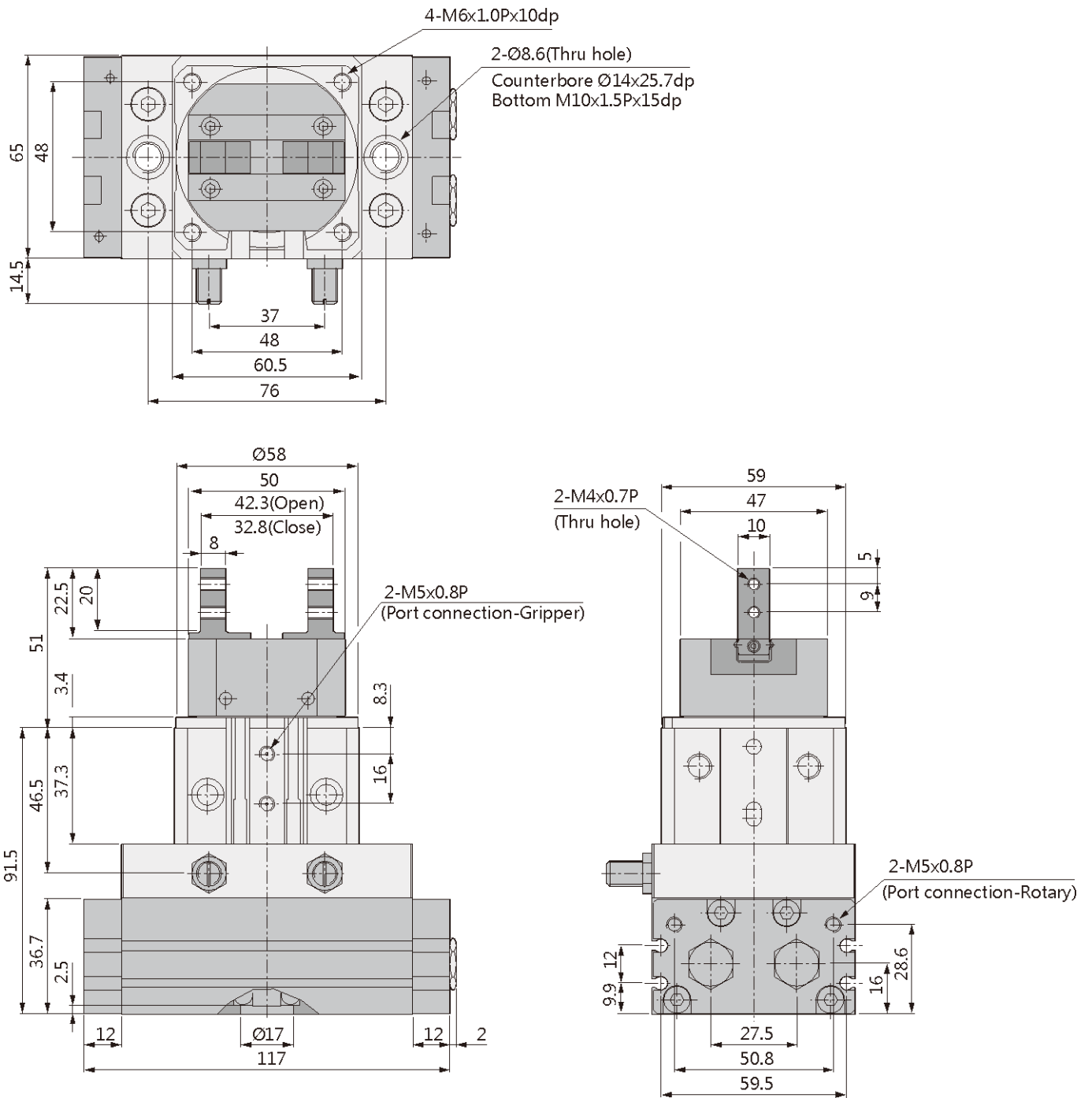



## ■ ABZ-25

