

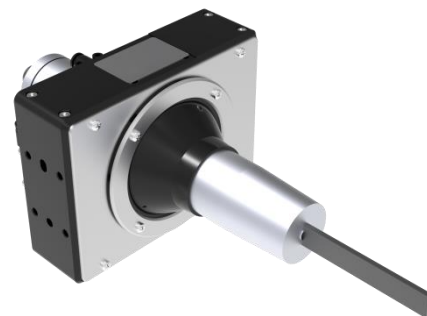

# Deburring & Grinding Tool

## Air shear machine-AC100F



 Burrs on the straight line



90° inner angle



Straight hole



Round hole



Outer circle



Cross



Hole back



Straight strip



Keyway

### Features

Ultra-small gap and median point error.

### Applicable Materials

Aluminum, copper, steel, plastic, composite materials, wood.

Function	Air shear machine
Chuck size	Φ5/Flat chisel
Floating pressure	0.1-0.5MPa
Floating stroke	+ -5.5°
Floating force	7-35N
Spindle pressure	0.6MPa
Weight	1.7kg
Dimensions (Length, Width, Height)	225 x 100 x 134
Rotational speed/Reciprocating frequency	9000BPM/10mm
Air consumption/Power	170LPM

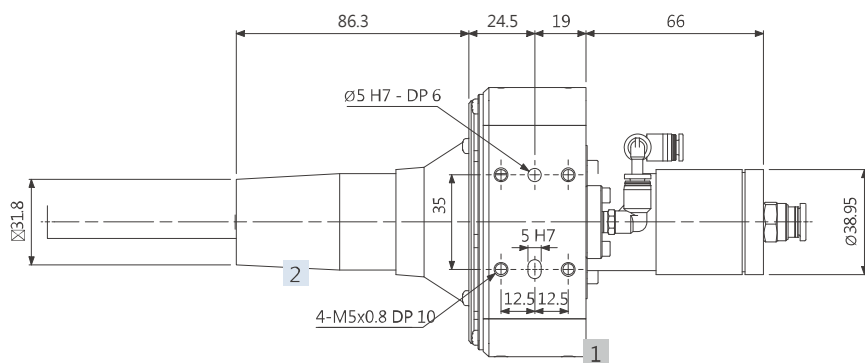

- 1 Floating seat
- 2 Pneumatic chisel machine
- 3 Chisel air supply
- 4 Floating air supply
- 5 Replacement consumables (chisels)

