



ADZM 系列

防塵型平行機械夾爪



產品特性

- 內置式感應磁石
- 滾柱型線軌
- 外加防塵套，可防止粉塵切屑侵入

產品規格

型號	ADZM-6	ADZM-10	ADZM-16	ADZM-20	ADZM-25	ADZM-32	ADZM-40
項目 \ 缸徑 mm	ø06	ø10	ø16	ø20	ø25	ø32	ø40
作動形式	複動型						
使用流體	空氣						
使用壓力範圍 kgf/cm ² (kPa)	2~7 (200~700)		1.5~7 (150~700)				
使用溫度範圍 °C	0~60						
最高作動頻度 次/min	100					60	
給油	無給油						
爪片開合精度 mm	±0.01					±0.02	
爪片開合行程 mm	4	4	6	10	14	22	30
接管口徑	M3 x 0.5P			M5 x 0.8P			
磁石裝置	附磁石						
重量 kg	0.025	0.06	0.14	0.27	0.49	1.81	1.37



訂購代號

ADZM-16-B-AMS-L
① ② ③

①

代號	缸徑 mm
6	ø6
10	ø10
16	ø16
20	ø20
25	ø25
32	ø32
40	ø40

②

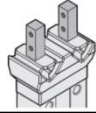
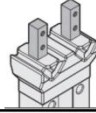
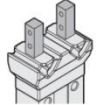
代號	夾爪型式
無記號：標準型	
B：側面攻牙型	
C：開關方向通孔型	

③



數據表

型號	最小作動壓力 kgf/cm ²	氣爪上螺紋孔 mm	有效夾持力 N	
			開	閉
ADZM-6	2	4-M2 x 0.4P	開	6.1
			閉	3.3
ADZM-10	2.2	4-M2.5 x 0.45P	開	17
			閉	11
ADZM-16	1.2	4-M3 x 0.5P	開	45
			閉	34
ADZM-20	1.5	4-M4 x 0.7P	開	66
			閉	42
ADZM-25	1.5	4-M5 x 0.8P	開	104
			閉	65
ADZM-32	1.5	4-M6 x 1.0P	開	193
			閉	158
ADZM-40	1.5	4-M8 x 1.25P	開	318
			閉	254



外徑夾持力特性圖

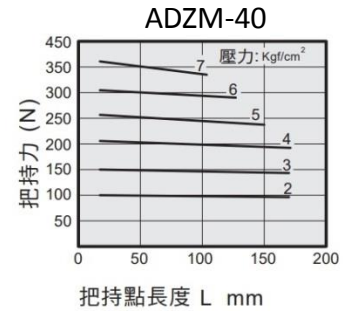
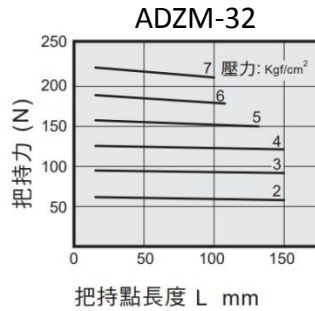
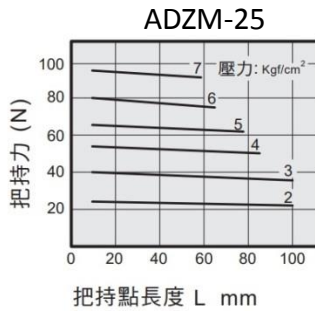
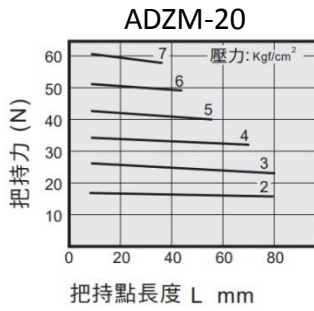
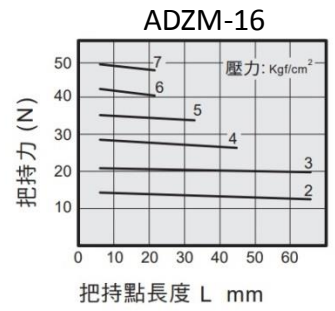
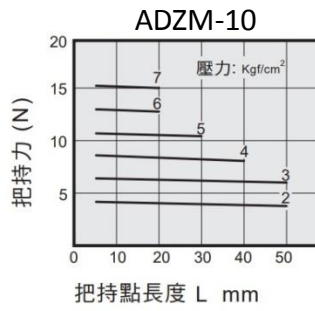
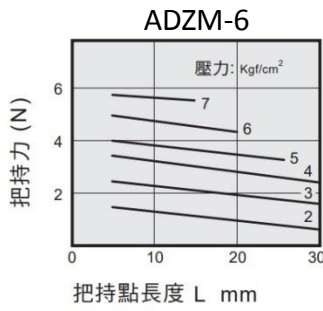
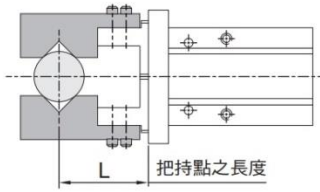

內徑夾持力特性圖

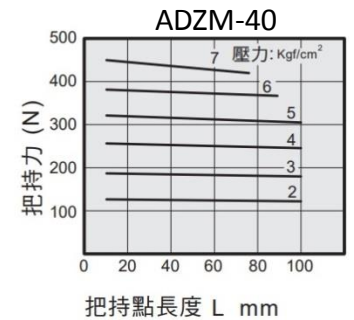
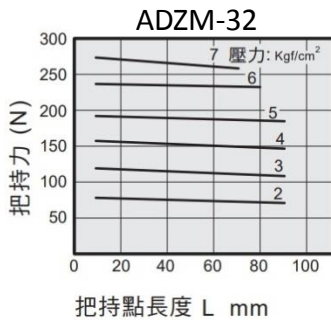
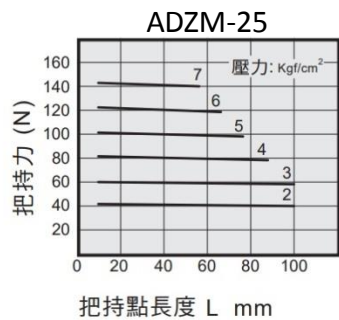
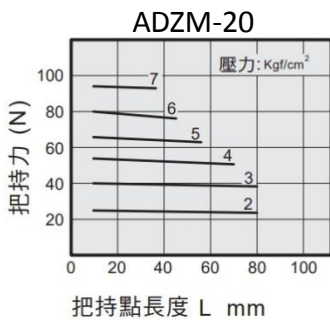
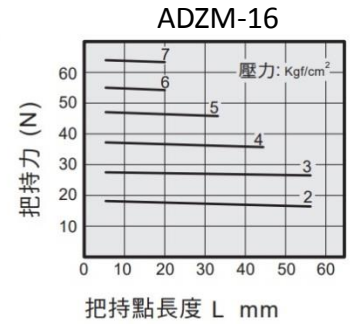
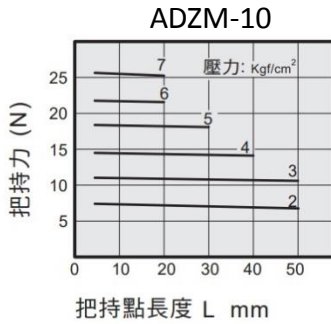
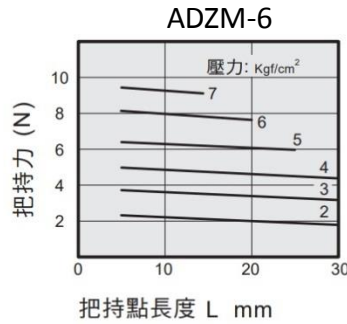
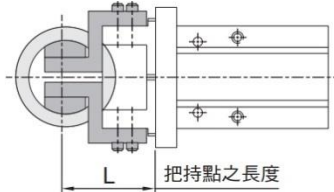



夾爪最大允許偏移量-外徑夾持

工件夾持請在允許範圍內使用，超出允許範圍對氣動夾爪的壽命會有不良影響。

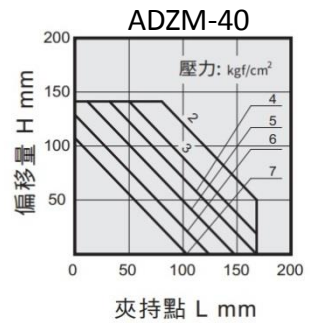
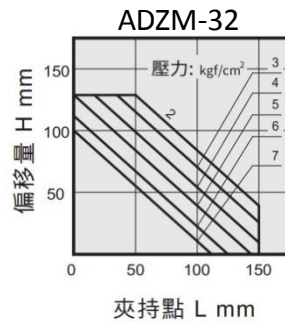
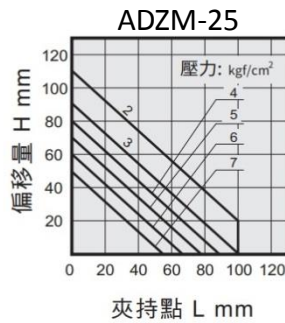
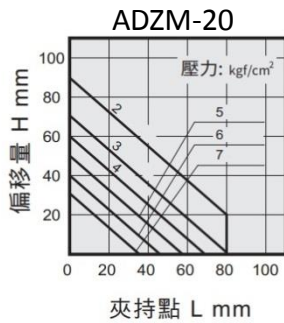
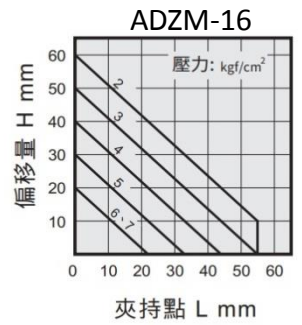
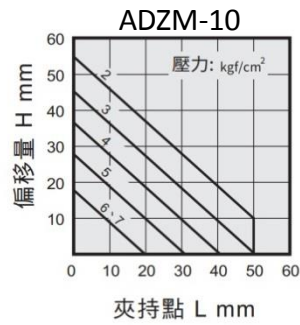
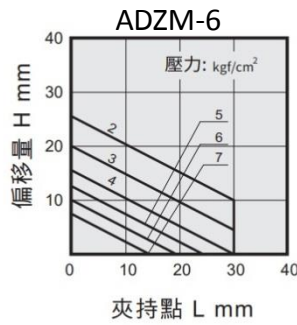
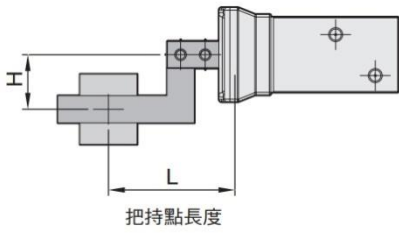

夾爪最大允許偏移量-內徑夾持

工件夾持請在允許範圍內使用，超出允許範圍對氣動夾爪的壽命會有不良影響。

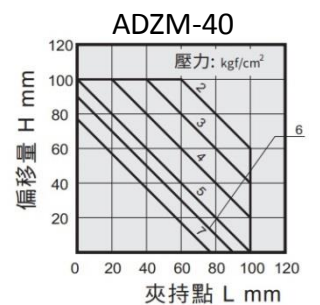
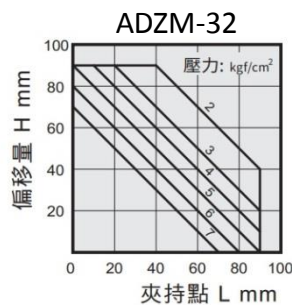
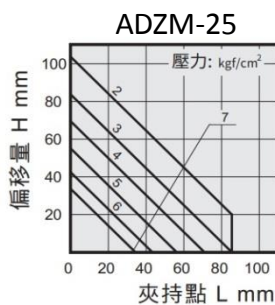
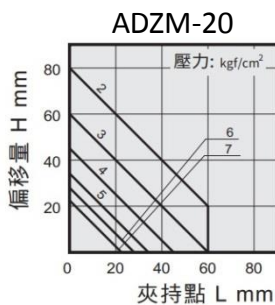
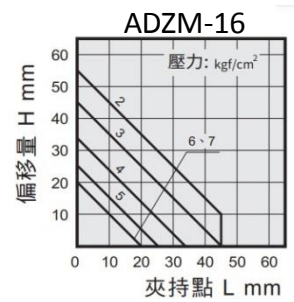
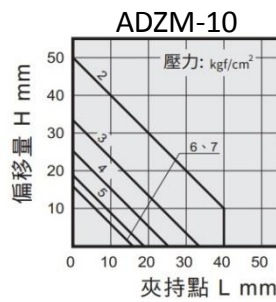
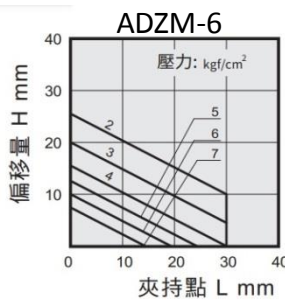
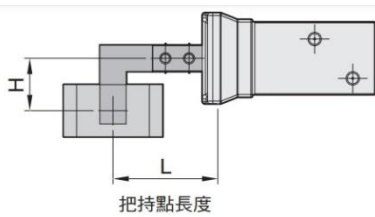



外觀尺寸

ADZM-6

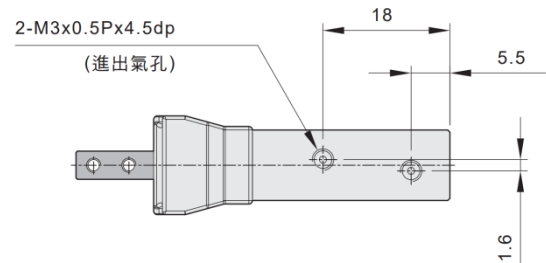
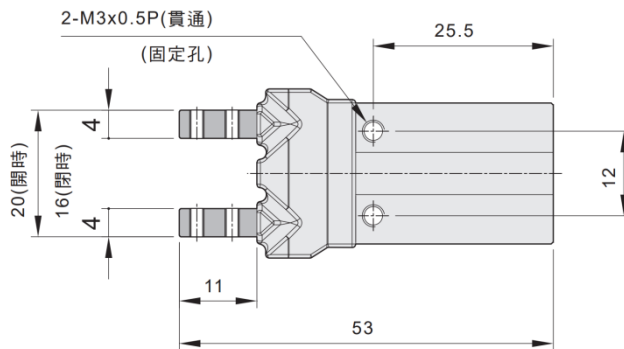
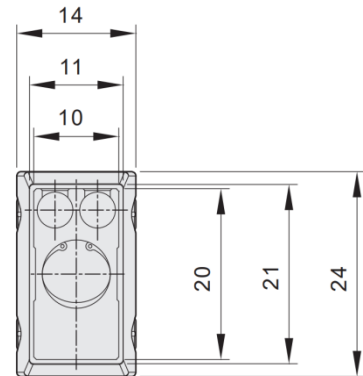
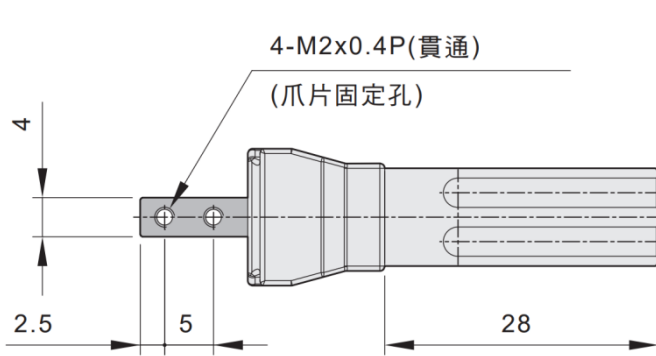

ADZM-10

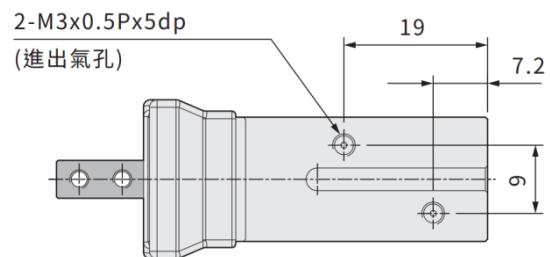
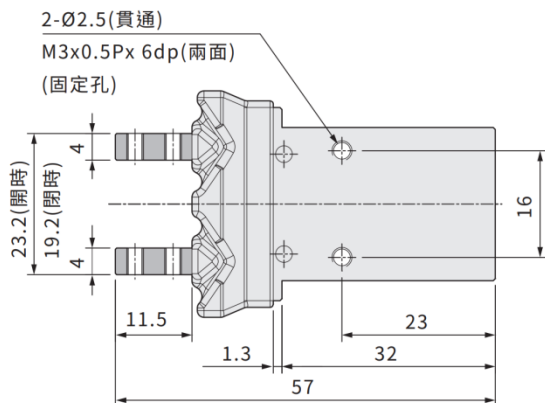
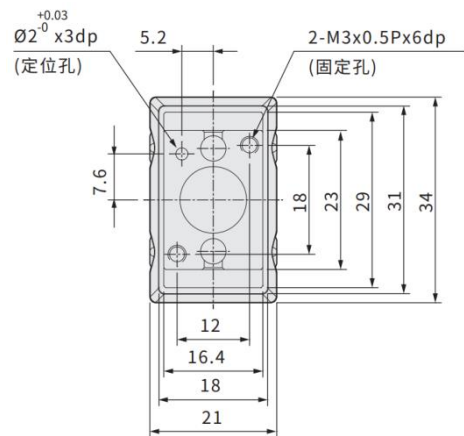
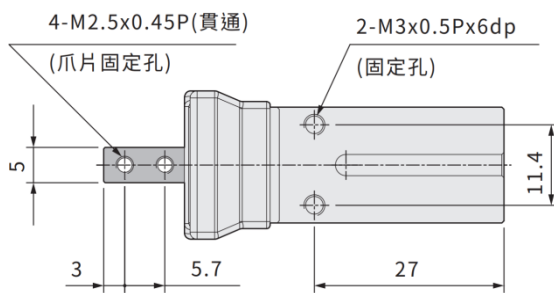



ADZM-16

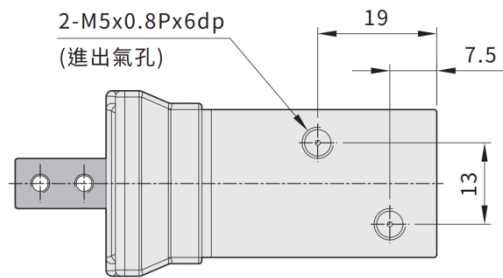
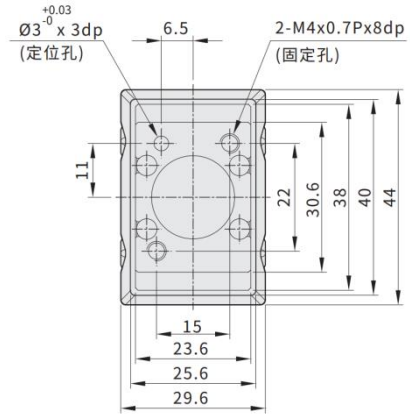
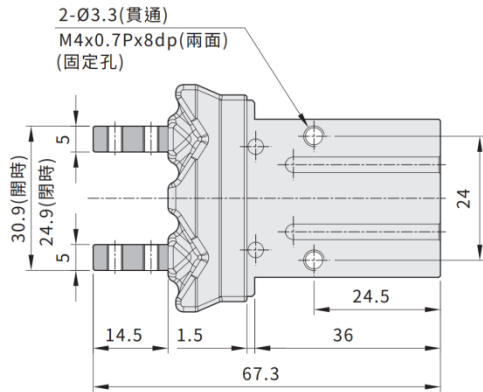
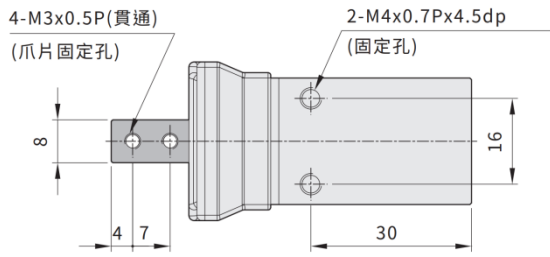

ADZM-20

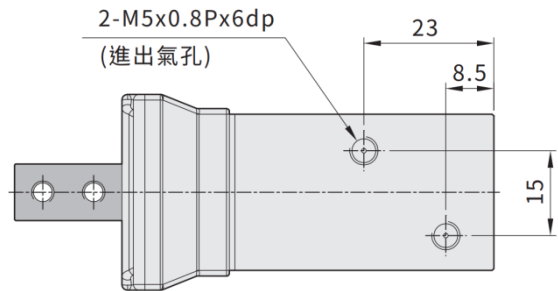
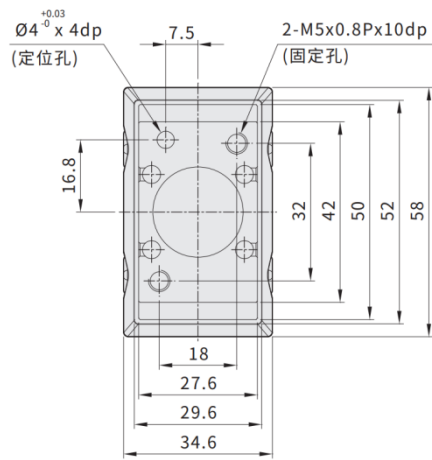
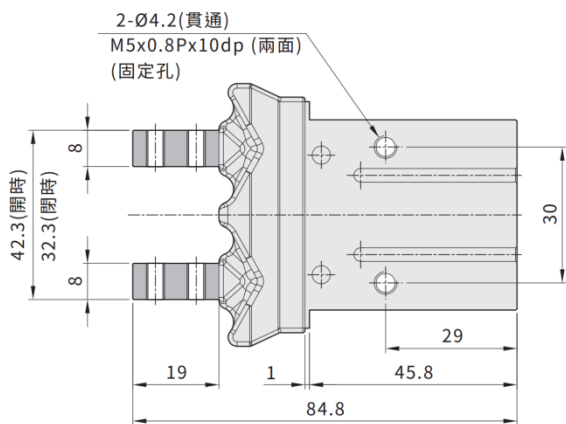
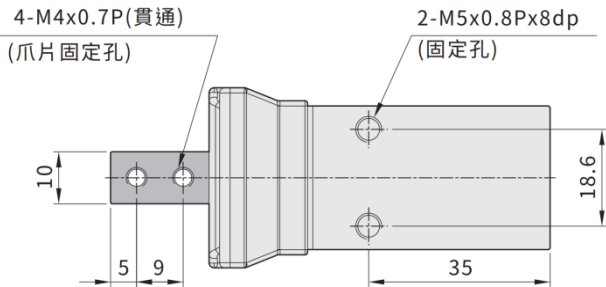



ADZM-25

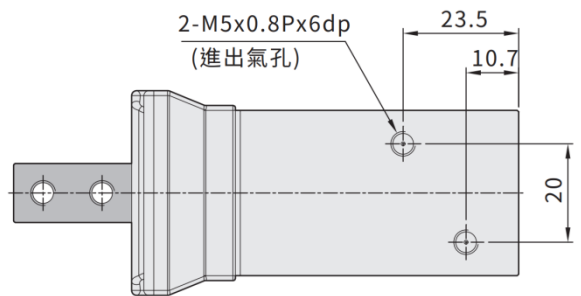
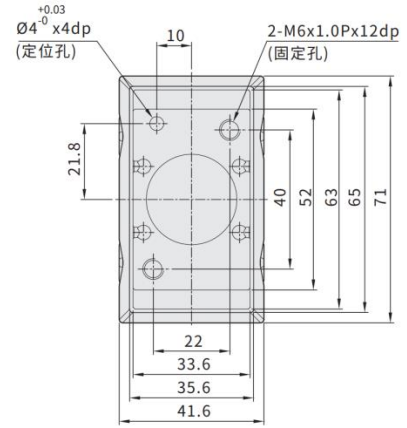
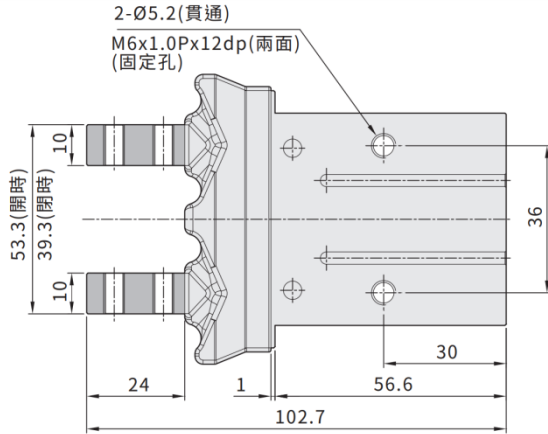
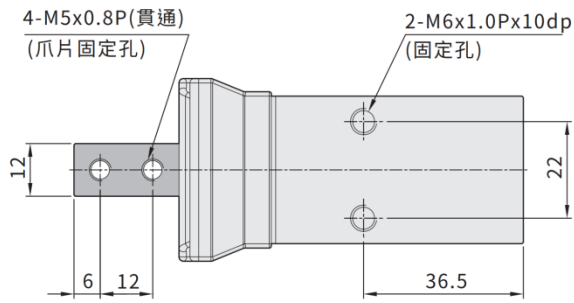

ADZM-32

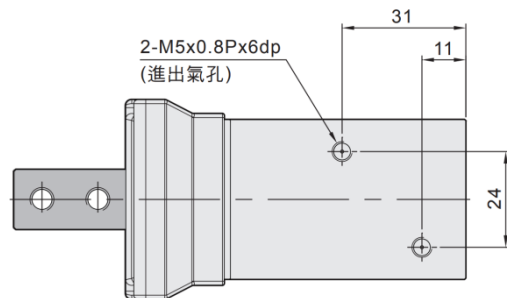
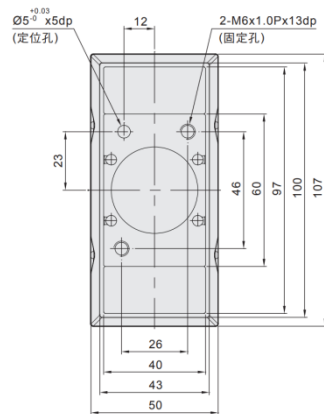
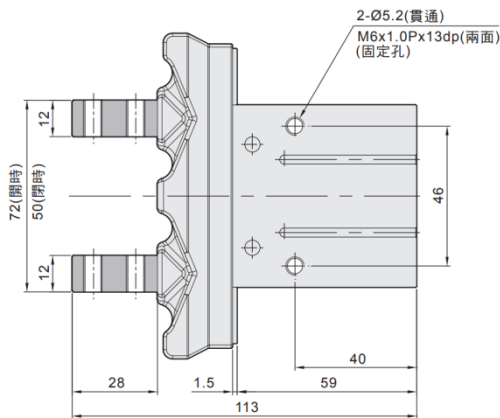
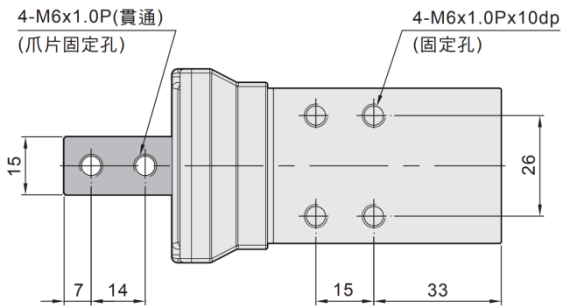



ADZM-40

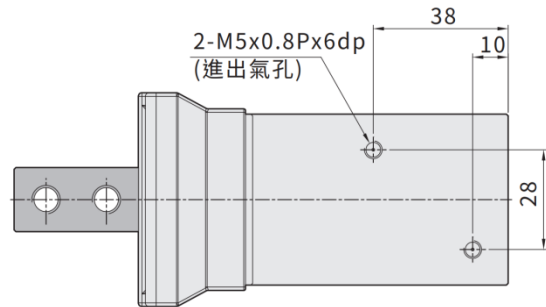
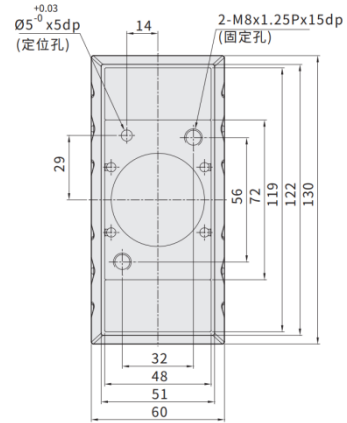
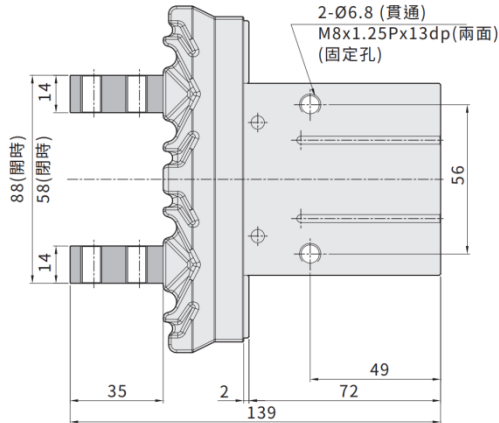
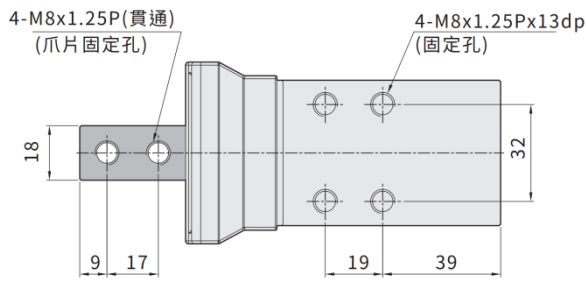

ADZM 側面攻牙型

單位：mm

型號 \ 代號	A	B	C	D
ADZM-6	2	2.5	5	M2 x 0.4P
ADZM-10	2	3	5.7	M2.5 x 0.45P
ADZM-16	2.5	4	7	M3 x 0.5P
ADZM-20	4	5	9	M4 x 0.7P
ADZM-25	5	6	12	M5 x 0.8P
ADZM-32	6	7	14	M6 x 1.0P
ADZM-40	7	9	17	M8 x 1.25P

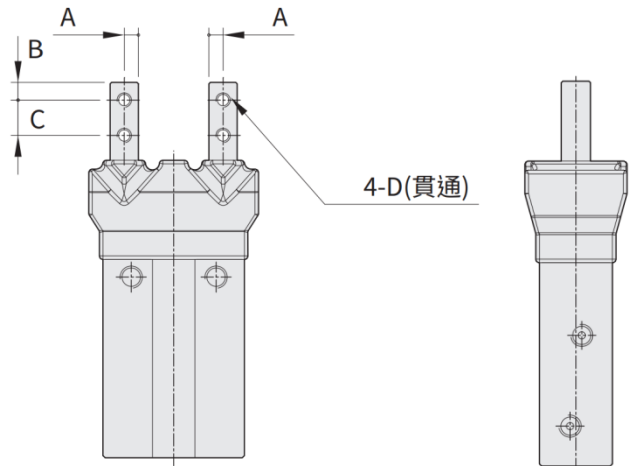



■ ADZM 開關方向通孔型

單位：mm

型號 \ 代號	A	B	C	D
ADZM-6	4	2.5	5	ø2.4
ADZM-10	5	3	5.7	ø3
ADZM-16	8	4	7	ø3.5
ADZM-20	10	5	9	ø4.5
ADZM-25	12	6	12	ø5.5
ADZM-32	15	7	14	ø6.5
ADZM-40	18	9	17	ø8.5

