

AJDR/AJDRN Electric Cylinder Actuators



Features

- Versatility and Control Combined: Discover the Power of Stepper Motor Actuators for Industrial Automation
- Maximize Reach in Minimal Space: Discover the Versatility of Telescoping Actuators for Precision Motion Control
- Unleash Extended Reach with Precision: Experience the Innovation of Telescoping Linear Actuators for Industrial Applications

AJDR-65

Order Code



AJDR - **65** - **P10** - **S100** - **1** - **C** - **S** - **J** - **4** - **V2**

AJDR	Product code	Electric cylinder
65	Body code	65
P10	Pitch	5 10 (mm)
S100	Effective stroke	50~500mm interval 50mm
1	Motor orientation	1 : Straight 2L : Left 2R : Right
C	Accuracy	C7 : ±0.01mm C5 : ±0.005mm C3 : ±0.0015mm
S	Sensor quantity	With 2 sensors
J	Sensor location	External
4	Motor capacity code 1	1 : 1000W 2 : 750W 3 : 400W 4 : 200W 5 : 100W 6 : Stepping motor B : Motor with Brake
V2	Motor capacity code 2	V1 : 110V V2 : 220V

■ Specifications

Motor Output		200W/ 200V	
Specified Torque		0.64 N.m	
Repetitive Position Precision		± 0.01 mm	
Drive Mechanism		Ball Screw C7	
Pitch Lead Screw		5 mm	10 mm
Highest Speed		250 mm/sec	500 mm/sec
MAX. Load	Horizontal	73 kg	35 kg
	Vertical	30 kg	18 kg
Specific Thrust		723 N	361 N
Drive Torque	Horizontal	0.15 N.m	0.2 N.m
	Vertical	0.3 N.m	0.11 N.m
Travel		500 mm~400 mm (40 mm interval)	
Max. RPM of Motor		3000 rpm	
Acceleration t:0.2 sec		1.25 M/sec ²	2.5 M/sec ²
Enviroment Temperature		5~45° C	
Sensor		Magnetic Switch x2	

■ AJDR-65 Specification of Direct Type

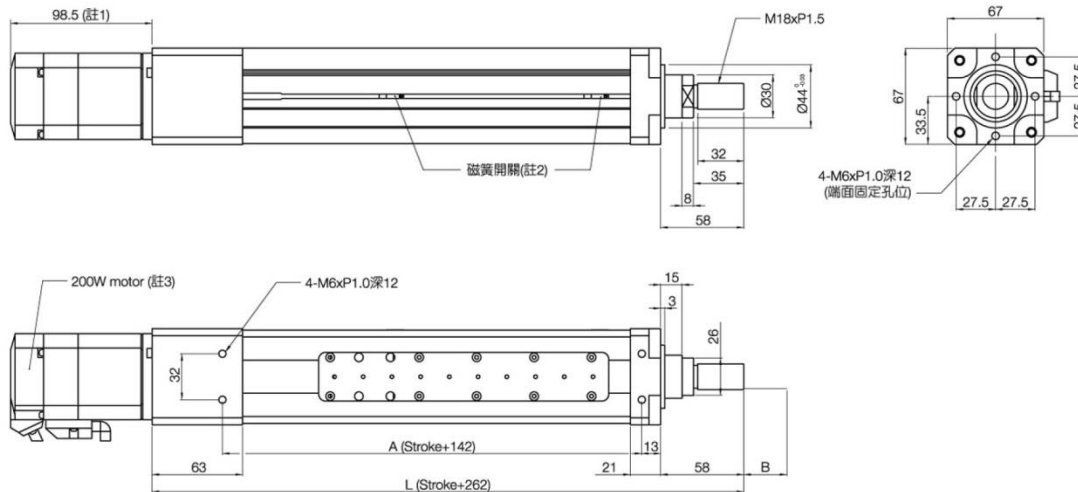

※重量不含馬達 單位：mm

行程Stroke	50	100	150	200	250	300	350	400	450	500
L	312	362	412	462	512	562	612	662	712	762
A	192	242	292	342	392	442	492	542	592	642
B	50	100	150	200	250	300	350	400	450	500
重量 Weight (kg)	3.5	4	4.6	5.1	5.6	6.2	7.2	7.8	8.4	9

1. The dimension of machine changes according to different motor.
2. Standard accessory: 2pc magnetic switch
3. Applicable motor: 100W, 200W, 400W

AJDR-65 Specification of Indirect Type-2L

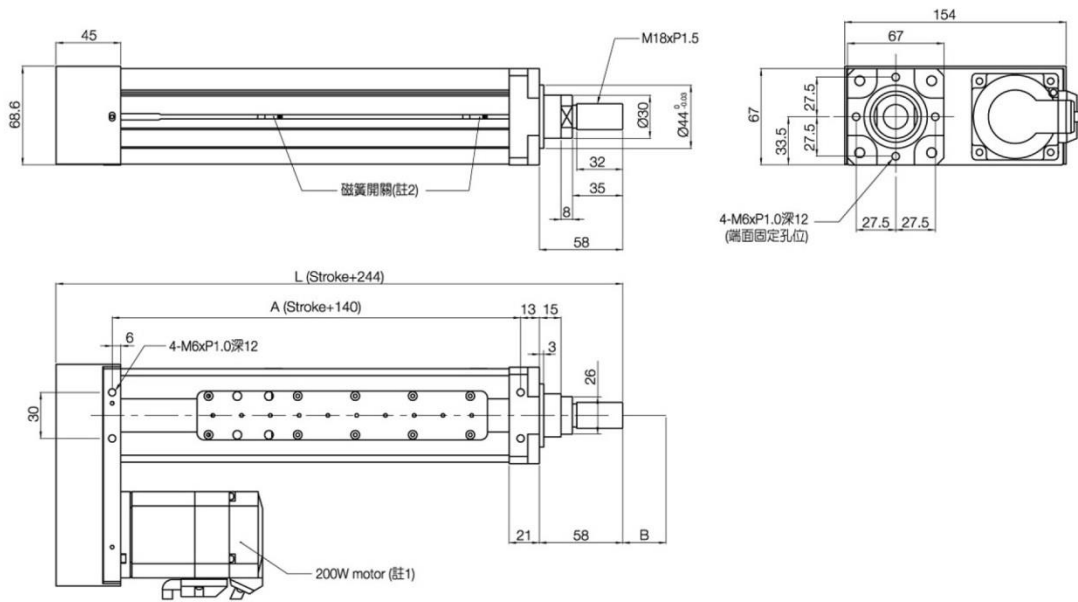

※重量不帶馬達 單位: mm

行程Stroke	50	100	150	200	250	300	350	400	450	500
L	294	344	394	444	494	544	594	644	694	744
A	190	240	290	340	390	440	490	540	590	640
B	50	100	150	200	250	300	350	400	450	500
重量 Weight (kg)	3.5	4	4.6	5.1	5.6	6.2	7.2	7.8	8.4	9

1. Applicable motor: 100W, 200W, 400W
2. Standard accessory: 2pc magnetic switch

AJDR-65 Specification of Indirect Type -2R

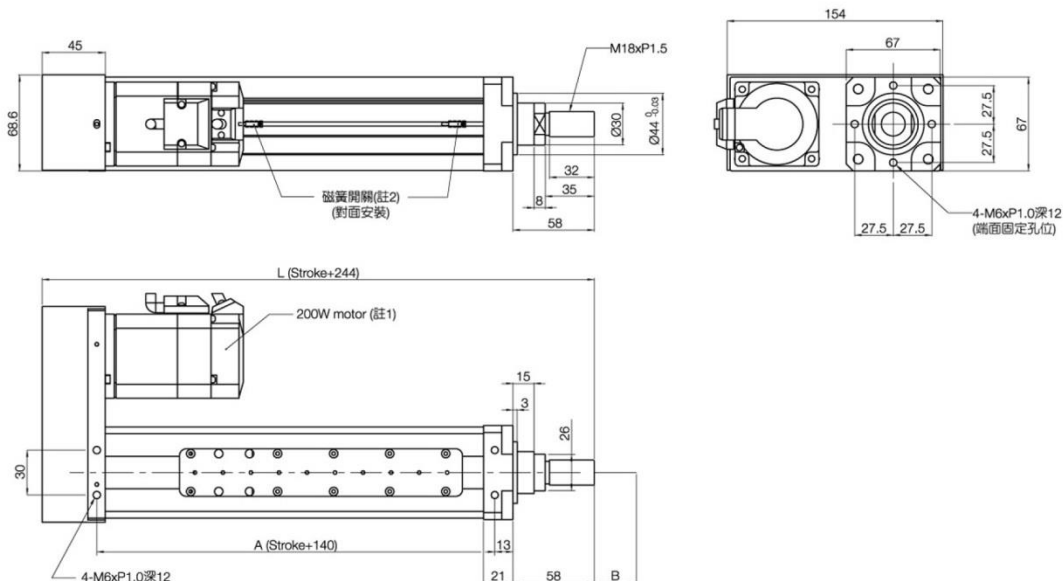

※重量不含馬達 單位: mm

行程Stroke	50	100	150	200	250	300	350	400	450	500
L	294	344	394	444	494	544	594	644	694	744
A	190	240	290	340	390	440	490	540	590	640
B	50	100	150	200	250	300	350	400	450	500
重量 Weight (kg)	3.5	4	4.6	5.1	5.6	6.2	7.2	7.8	8.4	9

1. Applicable motor: 100W, 200W, 400W
2. Standard accessory: 2pc magnetic switch

AJDRN-28

Order Code



AJDRN - **28** - **P01** - **S10** - **1** - **S** - **R** - **2ST** - **G2**

AJDRN	Product code	Electric cylinder
28	Body code	28 42 65 90
P01	Pitch	1 2 (mm)
S10	Effective stroke	10~170mm interval 10mm
1	Motor orientation	1 : Straight 2L : Left 2R : Right
S	Sensor quantity	With 2 sensors
R	Sensor location	R : Right L : Left
2ST	Flange fixing board	Stepping motor, 2ST : 2-phase 5ST : 5-phase Servo motor, SVM : Mitsubishi SVY : Yaskawa SVP : Panasonic SVT : Delta
G2	Reduction ratio	G2 =2:1 G3 =3:1 G4 =4:1 G5 =5:1

■ Specifications

Motor capacity	Stepping motor: 0.04 N.m	
ø8 Ball screw lead	1 mm	2 mm
Dynamic rated load	1600 ca(N)	1700 ca(N)
Static rated load	2500 coa(N)	2670 coa(N)
Repeat positioning precision	±0.02 mm(±10%deviation)	
linear speed	30 mm/sec	50 mm/sec
Horizontal thrust	30 kg	22 kg
Vertical thrust	14 kg	8 kg
Effective stroke	10mm~170mm (10mm interval)	
Acceleration	0.15 t	0.5 t
Vertical driving torque	0.025 Mta	0.029 Mta
Working temperature and humidity	0~40° C / 30~85° % RH	
Limit switches	DC24V 2 limit switches	
Rated thrust	226.2 N	113.1 N

Note: The accuracy can reach within 0.01mm if the output shaft is equipped with guide rail.

■ AJDRN-28 Direct Type

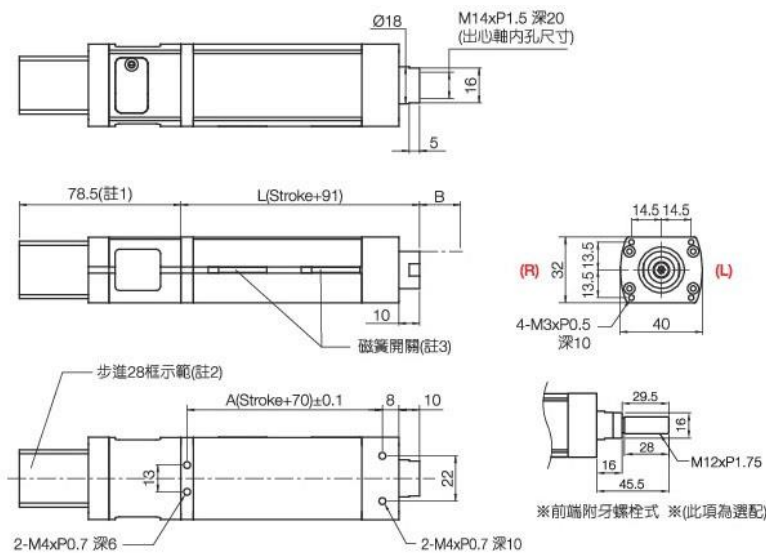

註1：長度依馬達不同而改變
 註2：適用步進馬達28樞(含)以下馬達
 註3：外置SENSOR安裝(可選擇R右側或L左側)

※重量不含馬達 單位：mm

行程Stroke	10	20	30	40	50	60	70	80
L	101	111	121	131	141	151	161	171
A	80	90	100	110	120	130	140	150
B	10	20	30	40	50	60	70	80
重量Weight (kg)	0.12	0.25	0.37	0.49	0.62	0.74	0.87	0.99

行程Stroke	90	100	110	120	130	140	150	160	170
L	181	191	201	211	221	231	241	251	261
A	160	170	180	190	200	210	220	230	240
B	90	100	110	120	130	140	150	160	170
重量Weight (kg)	1.12	1.24	1.36	1.49	1.61	1.74	1.86	1.98	2.1

AJDRN-28 Indirect Type-2L

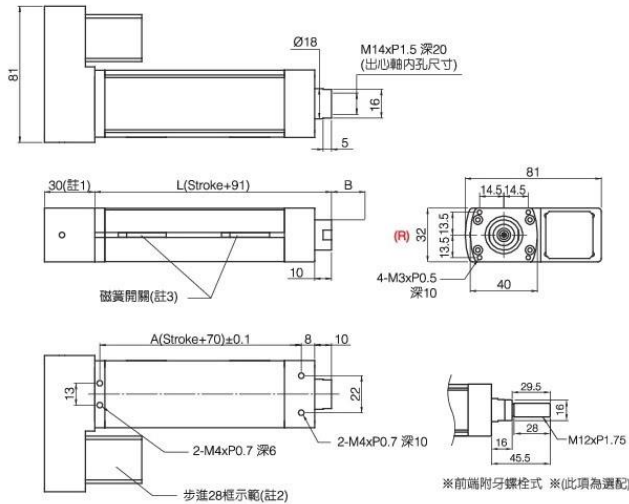

註1：長度依馬達不同而改變
 註2：適用步進馬達28框(含)以下馬達
 註3：外置SENSOR安裝R右側

※重量不含馬達 單位：mm

行程Stroke	10	20	30	40	50	60	70	80
L	101	111	121	131	141	151	161	171
A	80	90	100	110	120	130	140	150
B	10	20	30	40	50	60	70	80
重量Weight (kg)	0.08	0.15	0.23	0.3	0.38	0.46	0.53	0.61

行程Stroke	90	100	110	120	130	140	150	160	170
L	181	191	201	211	221	231	241	251	261
A	160	170	180	190	200	210	220	230	240
B	90	100	110	120	130	140	150	160	170
重量Weight (kg)	0.68	0.76	0.84	0.91	0.99	1.06	1.14	1.22	1.29

AJDRN-28 Indirect Type-2R

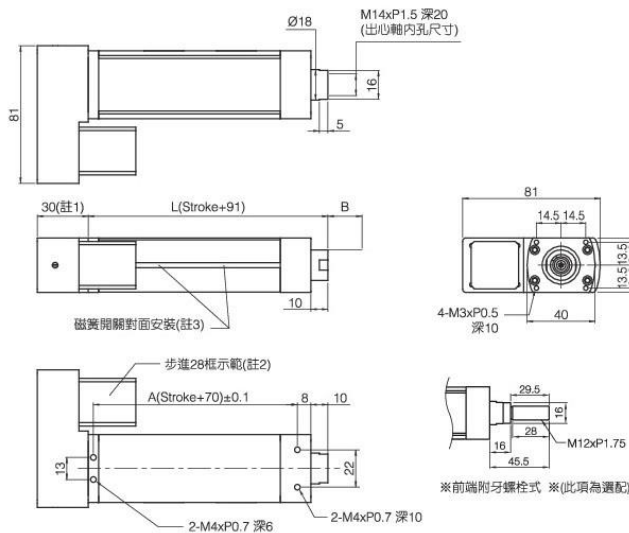

註1：長度依馬達不同而改變
 註2：適用步進馬達28框(含)以下馬達
 註3：外置SENSOR安裝L左側

※重量不含馬達 單位：mm

行程Stroke	10	20	30	40	50	60	70	80
L	101	111	121	131	141	151	161	171
A	80	90	100	110	120	130	140	150
B	10	20	30	40	50	60	70	80
重量Weight (kg)	0.08	0.15	0.23	0.3	0.38	0.46	0.53	0.61

行程Stroke	90	100	110	120	130	140	150	160	170
L	181	191	201	211	221	231	241	251	261
A	160	170	180	190	200	210	220	230	240
B	90	100	110	120	130	140	150	160	170
重量Weight (kg)	0.68	0.76	0.84	0.91	0.99	1.06	1.14	1.22	1.29

AJDRN-42



Order Code

AJDRN - **42** - **P05** - **S50** - **1** - **S** - **R** - **2ST** - **G2**

AJDRN	Product code	Electric cylinder	
42	Body code	28 42 65 90	
P05	Pitch	2 5 10 (mm)	
S50	Effective stroke	50~350mm interval 50 mm	
1	Motor orientation	1 : Straight 2L : Left 2R : Right	
S	Sensor quantity	With 2 sensors	
R	Sensor location	R : Right L : Left	
2ST	Flange fixing board	Stepping motor, 2ST : 2-phase 5ST : 5-phase Servo motor, SVM : Mitsubishi SVY : Yaskawa SVP : Panasonic SVT : Delta	
G2	Reduction ratio	G2 =2:1 G3 =3:1 G4 =4:1 G5 =5:1	

Specifications

Motor capacity	Stepping motor: 0.032 N.m		
ø10 Ball screw lead	2 mm	5 mm	10 mm
Dynamic rated load	2050 ca(N)	4200 ca(N)	4300 ca(N)
Static rated load	3250 coa(N)	6100 coa(N)	6250 coa(N)
Repeat positioning precision	±0.02 mm(±10% deviation)		
linear speed	50 mm/sec	250 mm/sec	5000 mm/sec
Horizontal thrust	68 kg	45 kg	32 kg
Vertical thrust	40 kg	23 kg	11 kg
Effective stroke	50mm~350mm (50mm interval)		
Acceleration	0.5 t	1.25 t	2.5 t
Vertical driving torque	0.15 Mta	0.24 Mta	0.23 Mta
Working temperature and humidity	0~40° C / 30~85° % RH		
Limit switches	DC24V 2 limit switches		
Rated thrust	904.7 N	361.9 N	180.95 N

Note: The accuracy can reach within 0.01mm if the output shaft is equipped with guide rail.

AJDRN-42 Direct Type

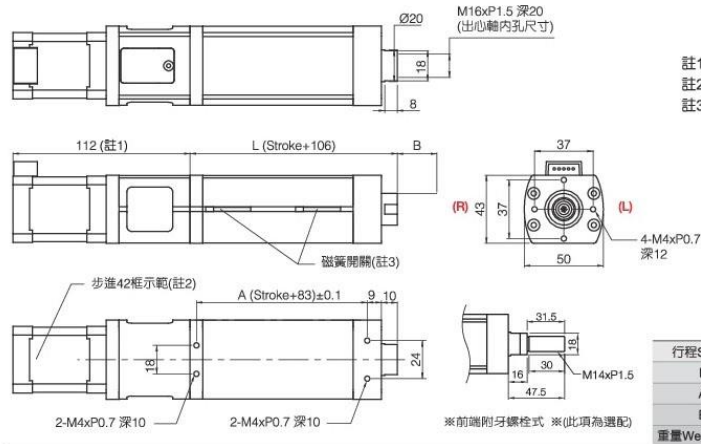

註1：長度依馬達不同而改變
 註2：適用步進馬達42框(含)以下馬達
 註3：外置SENSOR安裝(可選擇R右側或L左側)

※重量不含馬達 單位：mm

行程Stroke	50	100	150	200	250	300	350
L	156	206	256	306	356	406	456
A	133	183	233	283	333	383	433
B	50	100	150	200	250	300	350
重量Weight (kg)	1.06	2.12	3.18	2.42	5.3	6.36	7.42

AJDRN-42 Indirect Type-2L

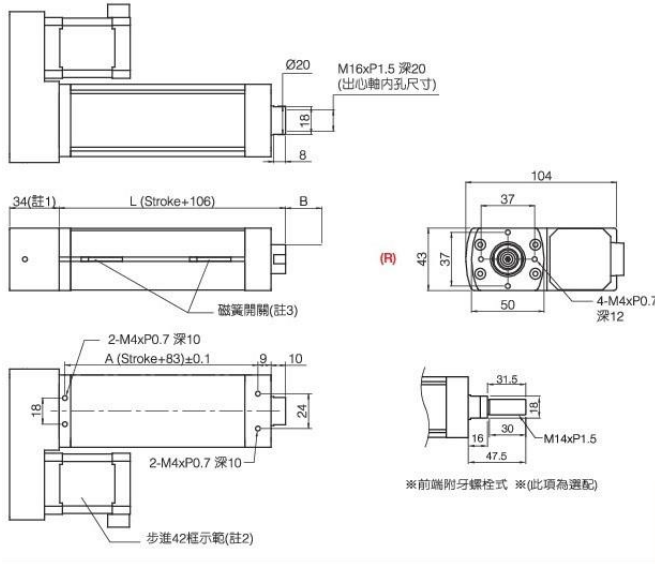

註1：長度依馬達不同而改變
 註2：適用步進馬達42框(含)以下馬達
 註3：外置SENSOR安裝R右側

※重量不含馬達 單位：mm

行程Stroke	50	100	150	200	250	300	350
L	156	206	256	306	356	406	456
A	133	183	233	283	333	383	433
B	50	100	150	200	250	300	350
重量Weight (kg)	0.94	1.88	2.82	3.76	4.7	5.64	6.58

AJDRN-42 Indirect Type-2R

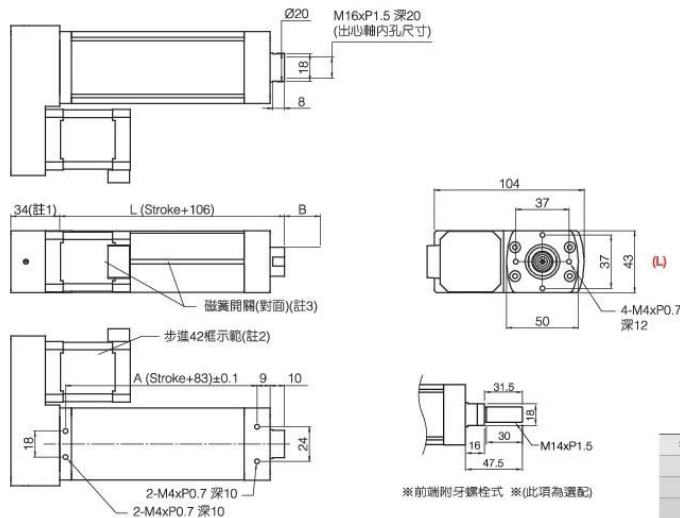

註1：長度依馬達不同而改變
 註2：適用步進馬達42框(含)以下馬達
 註3：外置SENSOR安裝L左側

※重量不含馬達 單位：mm

行程Stroke	50	100	150	200	250	300	350
L	156	206	256	306	356	406	456
A	133	183	233	283	333	383	433
B	50	100	150	200	250	300	350
重量Weight (kg)	0.94	1.88	2.82	3.76	4.7	5.64	6.58

AJDRN-65



Order Code

AJDRN - **65** - **P10** - **S50** - **1** - **S** - **R** - **2ST** - **G2**

AJDRN	Product code	Electric cylinder
65	Body code	28 42 65 90
P10	Pitch	5 10 16 20 (mm)
S50	Effective stroke	50~600mm interval 50mm
1	Motor orientation	1 : Straight 2L : Left 2R : Right
S	Sensor quantity	With 2 sensors
R	Sensor location	R : Right L : Left
2ST	Flange fixing board	Stepping motor, 2ST : 2-phase 5ST : 5-phase Servo motor, SVM : Mitsubishi SVY : Yaskawa SVP : Panasonic SVT : Delta
G2	Reduction ratio	G2 =2:1 G3 =3:1 G4 =4:1 G5 =5:1 G6 =6:1 G7 =7:1 G8 =8:1 G9 =9:1 G10 =10:1

Specifications

Motor capacity	Stepping motor: 1.3 N.m			
ø16 Ball screw lead	5 mm	10 mm	16 mm	20 mm
Dynamic rated load	1120 ca(N)	8390 ca(N)	5520 ca(N)	5540 ca(N)
Static rated load	25070 coa(N)	18210 coa(N)	11370 coa(N)	11700 coa(N)
Repeat positioning precision	±0.02 mm(±10% deviation)			
linear speed	250 mm/sec	500 mm/sec	800 mm/sec	1000 mm/sec
Horizontal thrust	200 kg	130 kg	70 kg	45 kg
Vertical thrust	70 kg	40 kg	23 kg	17 kg
Effective stroke	50mm~600mm (50mm interval)			
Acceleration	1.25 t	2.5 t	4 t	5 t
Vertical driving torque	0.88 Mta	0.87 Mta	0.9 Mta	0.89 Mta
Working temperature and humidity	0~40° C / 30~85° % RH			
Limit switches	DC24V 2 limit switches			
Rated thrust	1470 N	735.13 N	459.5 N	367.6 N

Note: The accuracy can reach within 0.01mm if the output shaft is equipped with guide rail.

AJDRN-65 Direct Type

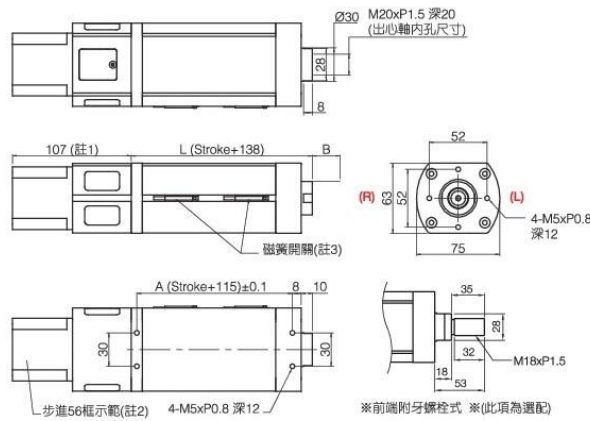

註1：長度依馬達不同而改變
 註2：適用步進馬達60框(含)以下馬達
 註3：外置SENSOR安裝(可選擇R右側或L左側)

※重量不含馬達 單位: mm

行程Stroke	50	100	150	200	250	300
L	188	238	288	338	388	438
A	165	215	265	315	365	415
B	50	100	150	200	250	300
重量Weight (kg)	2.62	5.24	7.86	10.48	13.1	15.72

行程Stroke	350	400	450	500	550	600
L	488	538	588	638	688	738
A	465	515	565	615	665	715
B	350	400	450	500	550	600
重量Weight (kg)	18.34	20.96	23.58	26	28.6	31.2

AJDRN-65 Indirect Type-2L

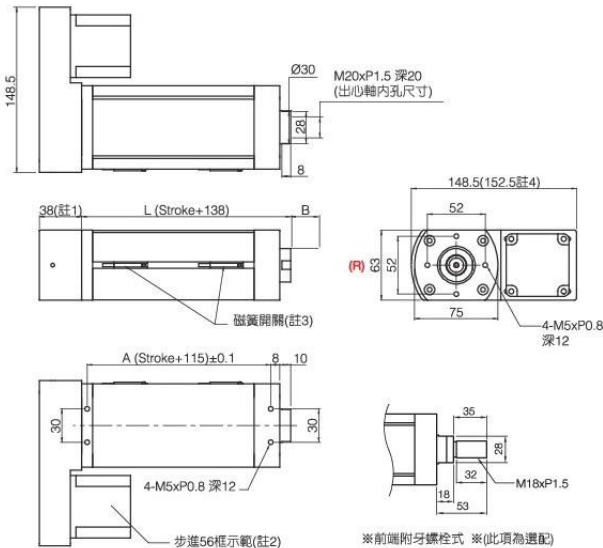

註1：長度依馬達不同而改變
 註2：適用步進馬達60框(含)以下馬達
 註3：外置SENSOR安裝R右側
 註4：60框何服時尺寸

※重量不含馬達 單位: mm

行程Stroke	50	100	150	200	250	300
L	188	238	288	338	388	438
A	165	215	265	315	365	415
B	50	100	150	200	250	300
重量Weight (kg)	2.53	5.06	7.59	10.12	12.65	15.18

行程Stroke	350	400	450	500	550	600
L	488	538	588	638	688	738
A	465	515	565	615	665	715
B	350	400	450	500	550	600
重量Weight (kg)	17.71	20.24	22.77	25.3	27.9	30.5

AJDRN-65 Indirect Type-2R

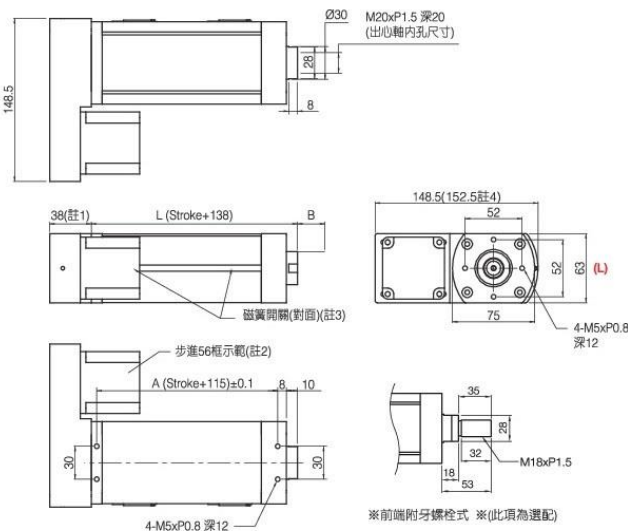

註1：長度依馬達不同而改變
 註2：適用步進馬達60框(含)以下馬達
 註3：外置SENSOR安裝L左側
 註4：60框何服時尺寸

※重量不含馬達 單位: mm

行程Stroke	50	100	150	200	250	300
L	188	238	288	338	388	438
A	165	215	265	315	365	415
B	50	100	150	200	250	300
重量Weight (kg)	2.53	5.06	7.59	10.12	12.65	15.18

行程Stroke	350	400	450	500	550	600
L	488	538	588	638	688	738
A	465	515	565	615	665	715
B	350	400	450	500	550	600
重量Weight (kg)	17.71	20.24	22.77	25.3	27.9	30.5

AJDRN-90



Order Code

AJDRN - **90** - **P10** - **S50** - **1** - **S** - **R** - **2ST** - **G2**

AJDRN	Product code	Electric cylinder
90	Body code	28 42 65 90
P10	Pitch	5 10 20 (mm)
S50	Effective stroke	50~900mm interval 50mm
1	Motor orientation	1 : Straight 2L : Left 2R : Right
S	Sensor quantity	With 2 sensors
R	Sensor location	R : Right L : Left
2ST	Flange fixing board	Stepping motor, 2ST : 2-phase 5ST : 5-phase Servo motor, SVM : Mitsubishi SVY : Yaskawa SVP : Panasonic SVT : Delta
G2	Reduction ratio	G2 =2:1 G3 =3:1 G4 =4:1 G5 =5:1 G6 =6:1 G7 =7:1 G8 =8:1 G9 =9:1 G10 =10:1

Specifications

Motor capacity	Stepping motor: 2.4 N.m		
ø20 Ball screw lead	5 mm	10 mm	20 mm
Dynamic rated load	14840 ca(N)	15160 ca(N)	7640 ca(N)
Static rated load	36810 coa(N)	38330 coa(N)	17580 coa(N)
Repeat positioning precision	±0.02 mm(±10% deviation)		
linear speed	250 mm/sec	500 mm/sec	1000 mm/sec
Horizontal thrust	750 kg	380 kg	100 kg
Vertical thrust	190 kg	83 kg	35 kg
Effective stroke	50mm~900mm (50mm interval)		
Acceleration	1.25 t	2.5 t	5 t
Vertical driving torque	1.86 Mta	1.81 Mta	1.83 Mta
Working temperature and humidity	0~40° C / 30~85° % RH		
Limit switches	DC24V 2 limit switches		
Rated thrust	2714.34 N	1357.17 N	678.6 N

Note: The accuracy can reach within 0.01mm if the output shaft is equipped with guide rail.

AJDRN-90 Direct Type

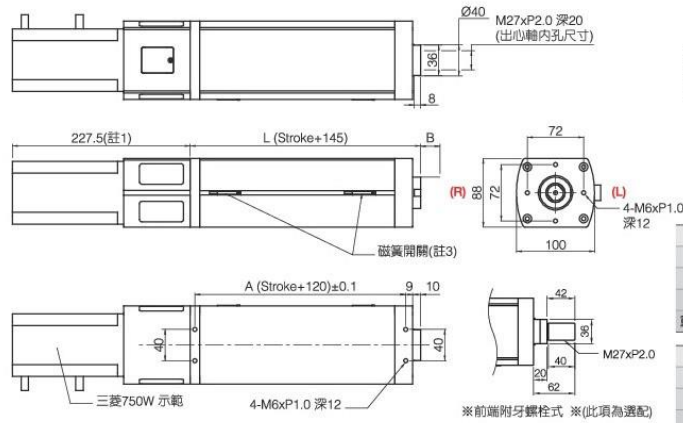

註1：長度依馬達不同而改變
 註2：適用步進馬達85框(含)以下馬達
 註3：外置SENSOR安裝(可選擇R右側或L左側)

※重量不含馬達 單位：mm

行程Stroke	50	100	150	200	250	300	350	400	450
L	195	245	295	345	395	445	495	545	595
A	170	220	270	320	370	420	470	520	570
B	50	100	150	200	250	300	350	400	450
重量Weight (kg)	5.16	10.32	15.48	20.64	25.8	30.96	36.12	41.28	46.44

行程Stroke	500	550	600	650	700	750	800	850	900
L	645	695	745	795	845	895	945	995	1045
A	620	670	720	770	820	870	920	970	1020
B	500	550	600	650	700	750	800	850	900
重量Weight (kg)	51.6	56.76	61.92	67.08	72.24	77.4	82.56	87.72	92.88

AJDRN-90 Indirect Type-2L

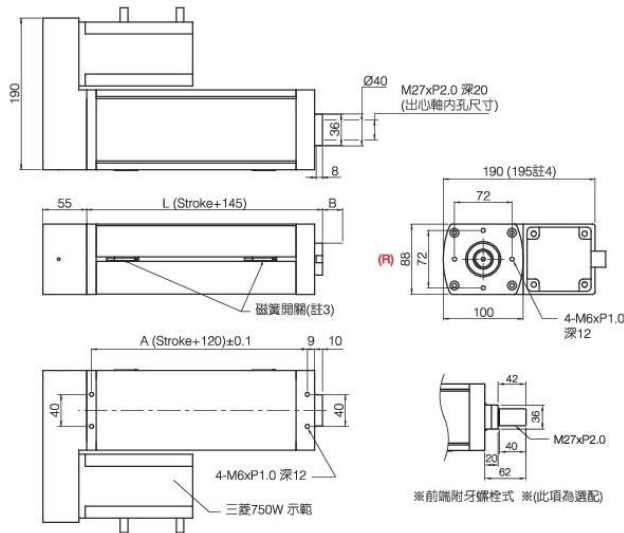

註1：長度依馬達不同而改變
 註2：適用步進馬達85框(含)以下馬達
 註3：外置SENSOR安裝R右側
 註4：85框步進馬達時尺寸

※重量不含馬達 單位：mm

行程Stroke	50	100	150	200	250	300	350	400	450
L	195	245	295	345	395	445	495	545	595
A	170	220	270	320	370	420	470	520	570
B	50	100	150	200	250	300	350	400	450
重量Weight (kg)	4.92	9.84	14.76	19.68	24.6	29.52	34.44	39.36	44.28

行程Stroke	500	550	600	650	700	750	800	850	900
L	645	695	745	795	845	895	945	995	1045
A	620	670	720	770	820	870	920	970	1020
B	500	550	600	650	700	750	800	850	900
重量Weight (kg)	49.2	54.12	59.04	63.96	68.88	73.8	78.72	83.64	88.56

AJDRN-90 Indirect Type-2R

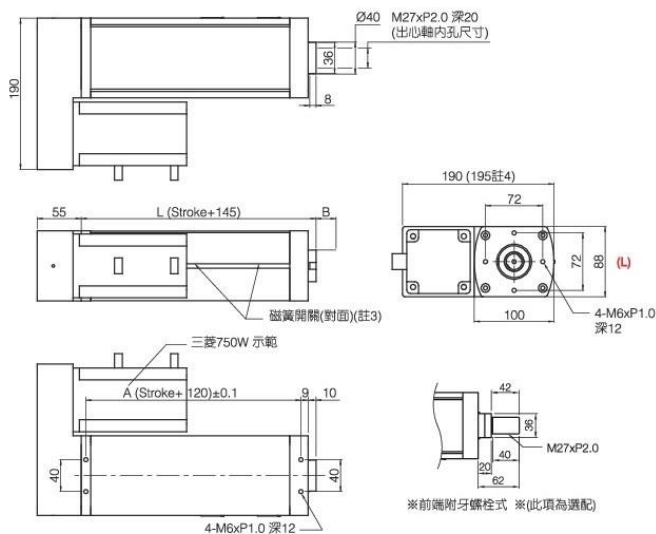

註1：長度依馬達不同而改變
 註2：適用步進馬達85框(含)以下馬達
 註3：外置SENSOR安裝L左側
 註4：85框步進馬達時尺寸

※重量不含馬達 單位：mm

行程Stroke	50	100	150	200	250	300	350	400	450
L	195	245	295	345	395	445	495	545	595
A	170	220	270	320	370	420	470	520	570
B	50	100	150	200	250	300	350	400	450
重量Weight (kg)	4.92	9.84	14.76	19.68	24.6	29.52	34.44	39.36	44.28

行程Stroke	500	550	600	650	700	750	800	850	900
L	645	695	745	795	845	895	945	995	1045
A	620	670	720	770	820	870	920	970	1020
B	500	550	600	650	700	750	800	850	900
重量Weight (kg)	49.2	54.12	59.04	63.96	68.88	73.8	78.72	83.64	88.56