

Deburring & Grinding Tool Pneumatic spindle-ALC400

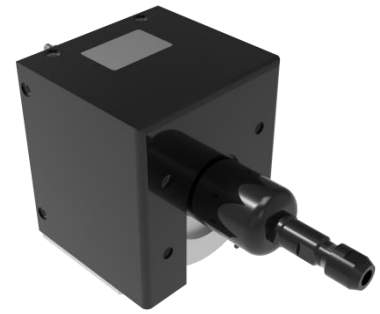

 Maze-like, large-area flat burrs.



Straight hole



Round hole



Outer circle



Inner circle



Cross



Hole back



Plane



Straight strip



Keyway

Features

Medium buoyancy, high cutting force.

Applicable Materials

Aluminum, copper.

Function	Pneumatic spindle
Chuck size	Φ6/Handle-mounted grinding material
Floating pressure	0.2-0.5Mpa
Floating stroke	Unidirectional 10mm
Floating force	26-66N
Spindle pressure	0.6MPa
Weight	3.15kg
Dimensions (Length, Width, Height)	233 x 100 x 117
Rotational speed/Reciprocating frequency	22000RPM
Air consumption/Power	450LPM

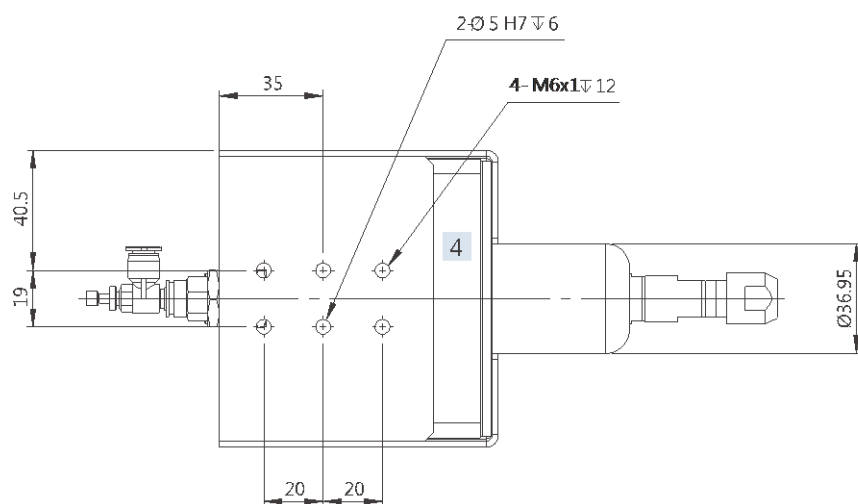
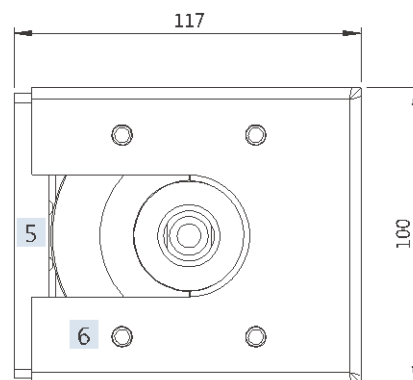
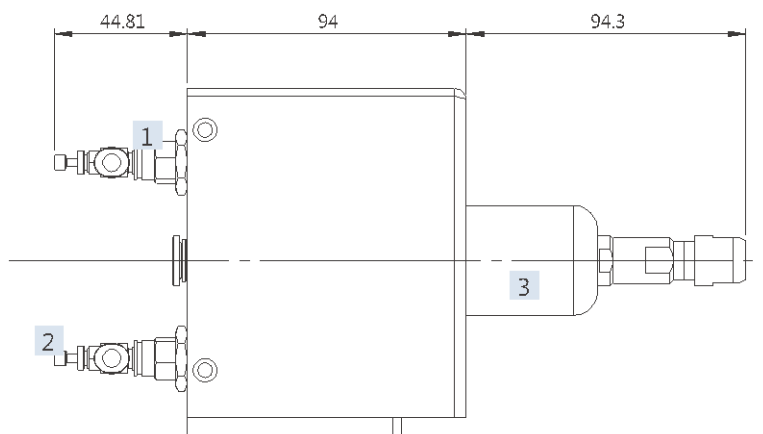

- 1 Floating component
- 2 Speed control joint
- 3 Grinder
- 4 Clamping seat
- 5 Base plate
- 6 Protective cover