

# Deburring & Grinding Tool

## Large-scale Z-axis floating module

### ALCZ200



☐ ? Depending on the tool



With a small grinding tool

### Features

Suitable for use with heavy-duty grinding tools.

### Applicable Materials

Depends on the tool.

Function	Large-scale Z-axis floating module (excluding the front grinding head)
Chuck size	none
Floating pressure	0.2-0.5MPa
Floating stroke	Unidirectional 40mm
Floating force	40-100N
Spindle pressure	none
Weight	2.4kg
Dimensions (Length, Width, Height)	120 x 120 x 195
Rotational speed/Reciprocating frequency	N/A
Air consumption/Power	N/A

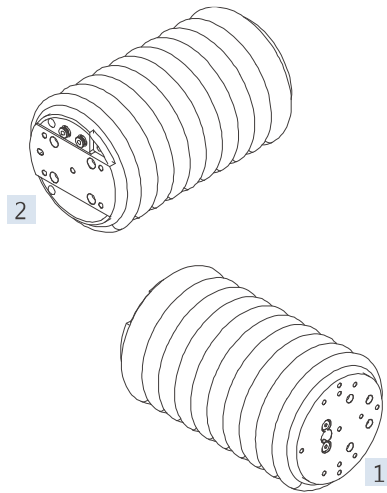
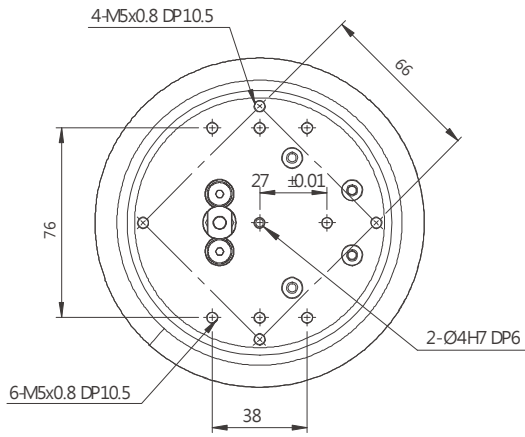

- 1 Tool end
- 2 Robot end
- 3 Telescopic dust cover
- 4 Extended air supply interface
- 5 Retractable air supply interface

