



浮動去毛刺-氣動主軸

ARC100

 複雜曲線上毛邊



直孔



圓孔



外圓



交叉



孔背



內圓



直條



鍵槽

特色

超小間隙及中位點誤差，超小浮動力

適用材質

鋁、銅、鋼

功能	氣動主軸
夾頭尺寸	Φ3/滾銑刀
浮動壓力	0.1-0.5MPa
浮動行程	徑向3.5°
浮動力	2-10N
主軸壓力	0.6MPa
重量	1.2kg
尺寸(長、寬、高)	195 x 82 x 92
轉速/往復頻率	65000RPM
耗氣量/功率	150LPM

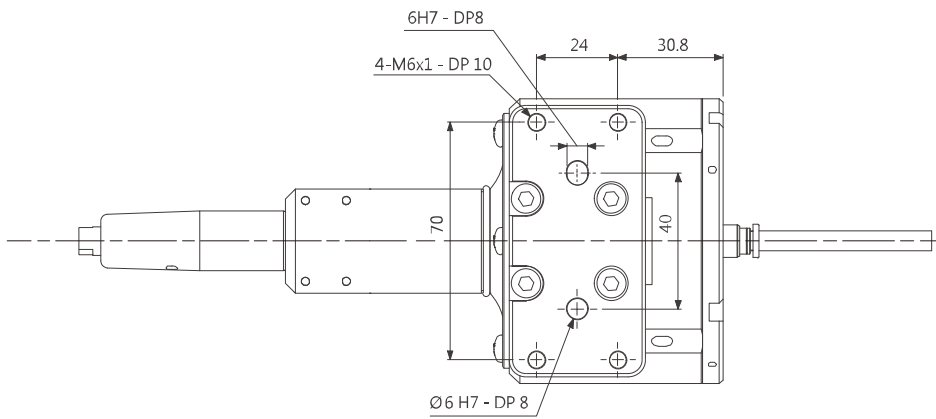
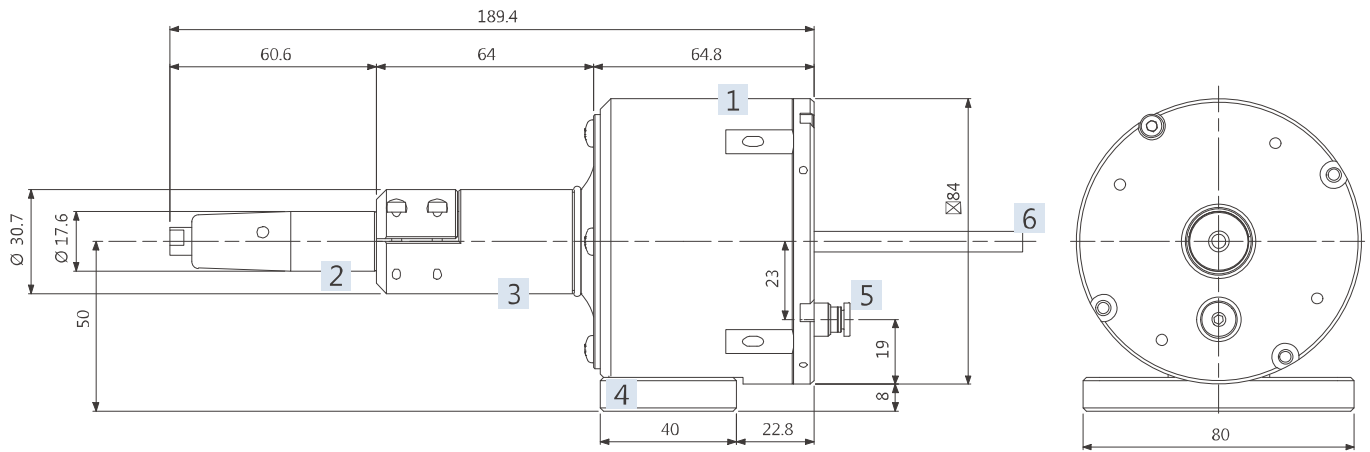

- 1 浮動座
- 2 氣動主軸
- 3 筒夾
- 4 轉接座
- 5 浮動氣源
- 6 主軸氣源