



浮動去毛刺-氣動主軸

ARC300



 複雜曲線上較大毛邊



直孔



圓孔



外圓



內圓



交叉



孔背



直條



鍵槽

特色

超小間隙及中位點誤差

適用材質

鋁、銅、鋼

功能	氣動主軸
夾頭尺寸	Φ6/滾銑刀
浮動壓力	0.1-0.5MPa
浮動行程	徑向3.5°
浮動力	6-30N
主軸壓力	0.6MPa
重量	2.9kg
尺寸(長、寬、高)	180 x 130 x 140
轉速/往復頻率	25000RPM
耗氣量/功率	350LPM

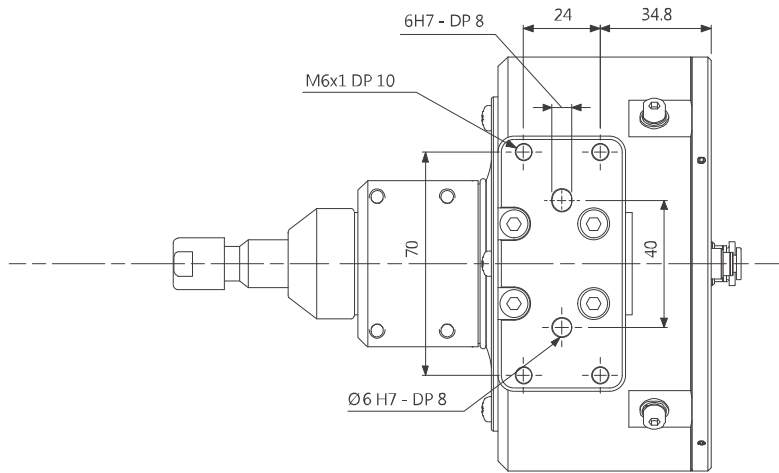
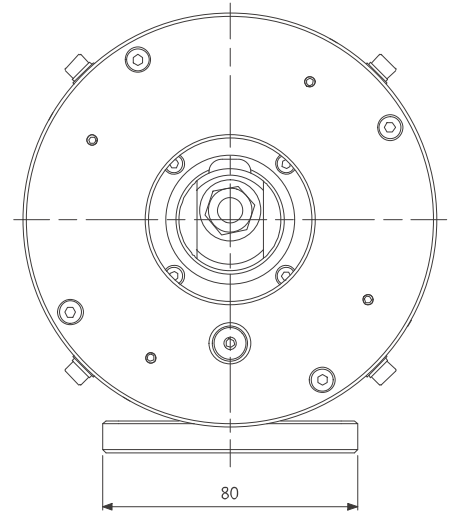
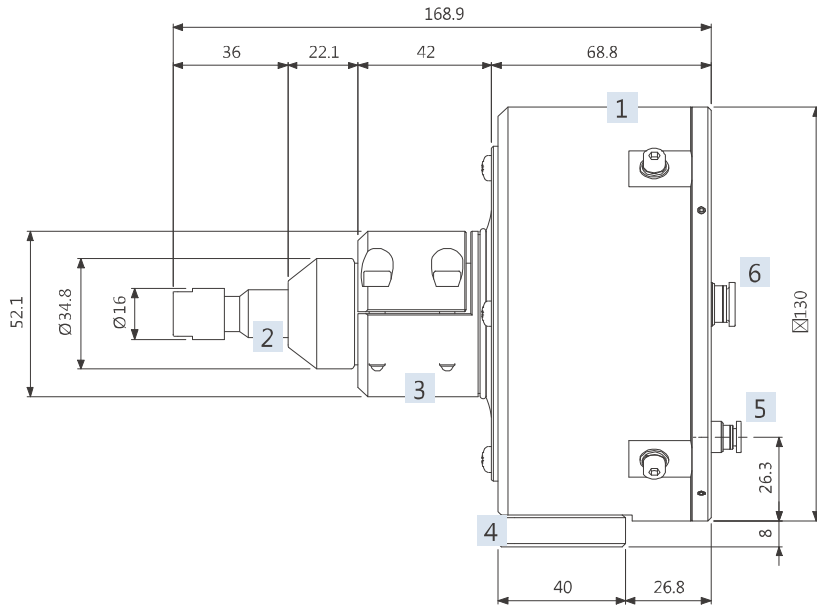

- 1 浮動座
- 2 氣動主軸
- 3 筒夾
- 4 轉接座
- 5 浮動氣源
- 6 主軸氣源