



# SAFETY LIGHT CURTAIN

**N series Area sensor**

**F series Thin Area sensor**

**MS series Thin Area sensor**

**M series Thin Area sensor**

**LX series Thin Area sensor**

**EX series Diffusion reflection**



Certificate number : 79Q13722

# Area Sensors

## 1 Select the light curtain through the required detection capability

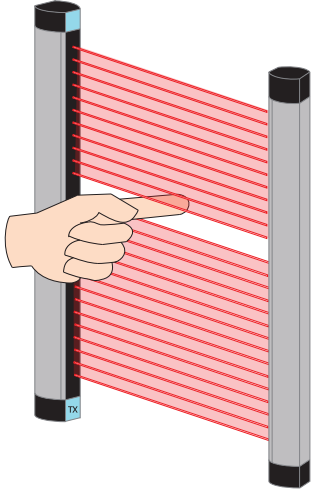

Detection capability 14mm  
Detect finger

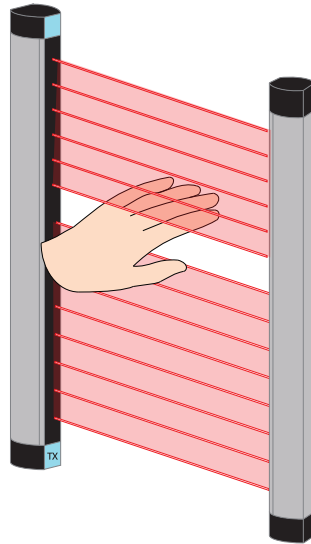

Detection capability 25mm  
Detect hand (palm)

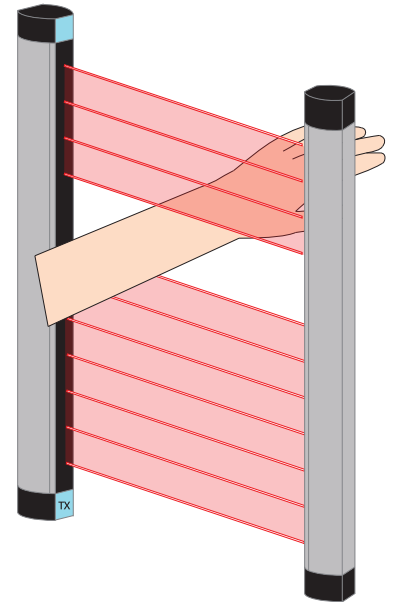

Detection capability 45mm  
Detect wrist

Additional customized services  
Detection capability  $\geq 70$ mm

## 2 Select the light curtain through characteristics

### N series



P.2

Universal  
Various of detection capability

### M series

Slim design  
Indicator light  
Adjusting switcher



P.10

### LX series

Slim design  
Side installation



P.18

### F series

Slim design  
Anti-disturbance light



P.6

### MS series

Slim design  
Special range  
Anti-disturbance light



P.15

### EX series

Diffusion reflection  
Unilateral installation



P.21

# N series

## Area sensor

### Applications

- Injection molding machine
- Packing Line Orientation Control
- Object sensing
- Automation industry sensing
- Parking equipment sensing
- Part picking detection
- Assembly line direction control

### Introduction

The N-series area sensing light curtains are versatile in terms of price and variety, and are easy to meet customer needs. They are the most suitable for use in a wide range of sensing light curtains for area detection, protection, inspection and discrimination. Instruction LVD requirements, with CE marking.



### Property

- Various type, 40mm(NA) · 25mm(NB) · 70mm(NC) and ND ( $\geq 70$ ) series through customized detect capabilities
- The most long-range detection of up to 7m; customized range up to 15m.
- Detection zone:70mm ~ 1720mm.
- Optional cross or parallel light to increase the scan range.
- Provide NPN or PNP selection.
- Installation and calibration easy.
- Quality and stability, price concessions.

### General Specifications

Model	NA	NB	NC	ND
Beam axis pitch	40mm	25mm	70mm	$\geq 70$ mm
Detection zone	120 mm ~ 1720 mm	75 mm ~ 1575 mm	70 mm ~ 770 mm	
Operating distance	0.5m ~ 1.5 m ( LOW ) · 1m ~ 3 m ( HI ) · 1m ~ 7 m ( L )			
Reaction time	20msec (It does not include relay switch time)			
Classification	CE LVD ; No safety certification (do not use in dangerous equipment)			
Power supply	24VDC $\pm$ 20%			
Power consumption	Basic 40mA ; 8mA more for each axis, up to 400mA			
Output mode	One set of outputs (NPN); model plus P (PNP output)			
Appearance	Aluminum ; Silver coating(standard) ; Yellow coating(select)			
Connector	M12connector(TX:Gray RX:Black)			
Ambient temperature	0°C to +50°C			
Enclosure rating	IP65			

# N Area sensor

## NA series

Detection Capability 45mm

Beam axis pitch : 40mm		Standard Operating distance 0.5m to 3m L type Operating distance 1m to 7m			
Model	Beams	Detection Zone (K)(mm)	Overall Length (B)(mm)	Install Length (C)(mm)	Assembly Length (D)(mm)
*NA-4	4	120	215	252	277
*NA-6	6	200	295	332	357
*NA-8	8	280	375	412	437
*NA-10	10	360	455	492	517
*NA-12	12	440	535	572	597
*NA-14	14	520	615	652	677
*NA-16	16	600	695	732	757
*NA-20	20	760	855	892	917
*NA-24	24	920	1015	1052	1077
*NA-28	28	1080	1175	1212	1237
*NA-32	32	1240	1335	1372	1397
*NA-36	36	1400	1495	1532	1557
*NA-40	40	1560	1655	1692	1717
*NA-44	44	1720	1815	1852	1877

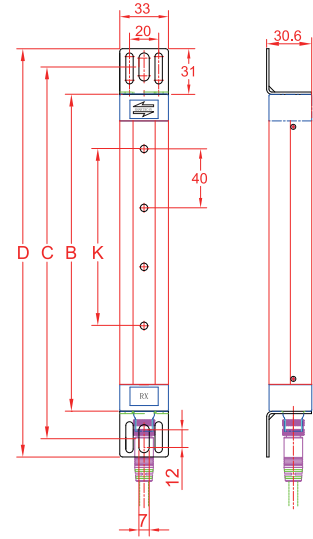

NA Dimensions

## NB series

Detection Capability 30mm

Beam axis pitch : 25mm		Standard Operating distance 0.5m to 3m L type Operating distance 1m to 7m			
Model	Beams	Detection Zone (K)(mm)	Overall Length (B)(mm)	Install Length (C)(mm)	Assembly Length (D)(mm)
*NB-4	4	75	164	201	226
*NB-8	8	175	264	301	326
*NB-12	12	275	364	401	426
*NB-16	16	375	464	501	526
*NB-20	20	475	564	601	626
*NB-24	24	575	664	701	726
*NB-32	32	775	864	901	926
*NB-40	40	975	1064	1101	1126
*NB-48	48	1175	1264	1301	1326
*NB-56	56	1375	1464	1501	1526
*NB-64	64	1575	1664	1701	1726

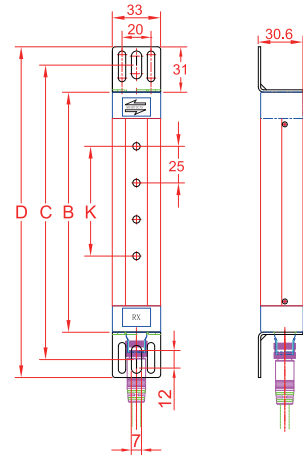

NB Dimensions

## NC series

Detection Capability 75mm

Beam axis pitch : 70mm		Standard Operating distance 0.5m to 3m ※NC series is cross light and PNP output			
Model	Beams	Detection Zone (K)(mm)	Overall Length (B)(mm)	Install Length (C)(mm)	Assembly Length (D)(mm)
*NC-2	2	70	149	186	211
*NC-3	3	140	219	256	281
*NC-4	4	210	289	326	351
*NC-5	5	280	359	396	421
*NC-6	6	350	429	466	491
*NC-7	7	420	499	536	561
*NC-8	8	490	569	606	631
*NC-9	9	560	639	676	701
*NC-10	10	630	709	746	771

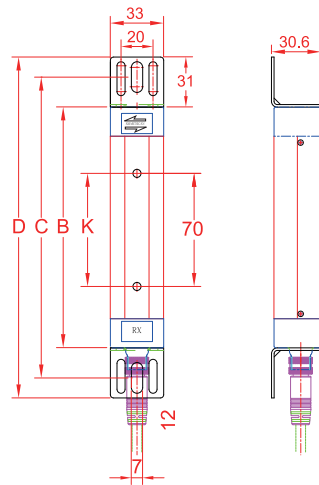

NC Dimensions

## ND series

Additional customized services  
Detection capability  $\geq 70$ mm

Beam axis pitch : $\geq 70$ mm		Standard Operating distance 0.5m to 3m	
Detection Capability : $\geq 75$ mm		L type Operating distance 1m to 7m	

Customized service description of N series :

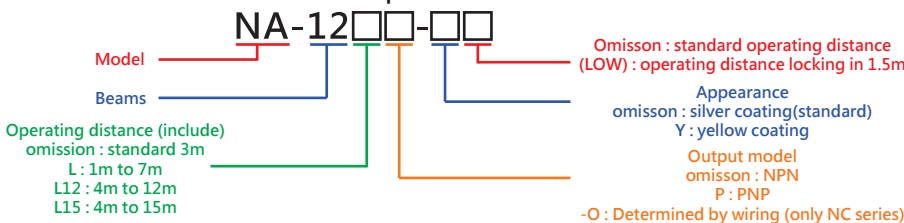

※ SMARTSCAN provide customized services.  
Please connect with our sales.

### NA · NB Electric Connection

Standard model: It has a set of independent NPN (crystal NO/NC contact) output current of 200mA; when the light curtain is normally operated, the black wire is turned on to 0V, and there is no conduction when shielding.

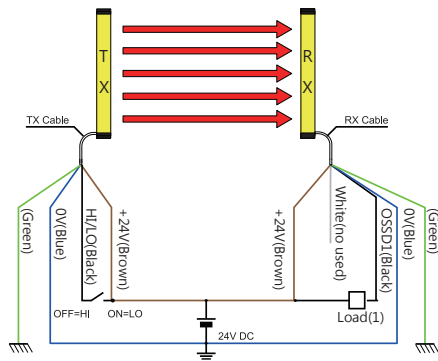

Standard model receiver (1 set of NPN)

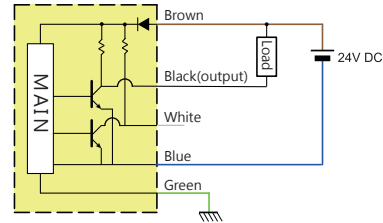

Select model P: has an independent PNP output current of 200mA; when the light curtain is normally activated, the black line output is +24V, and there is no output when blocking.

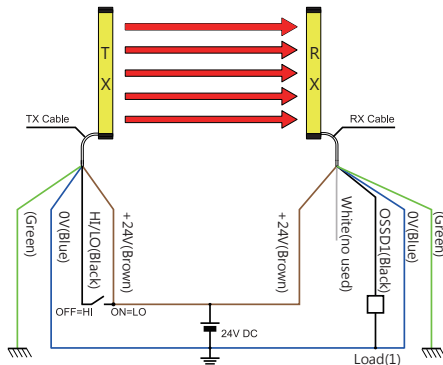

Select model receiver (1 set of PNP)

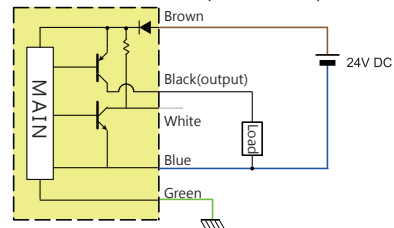

### NC Electric Connection

Standard model: It has an independent PNP output. When the light curtain is normally operated, the black line output is +24V, and the maximum current is about 20mA. When it is shielded, it can be turned on to 0V, and the maximum current can be 40mA.

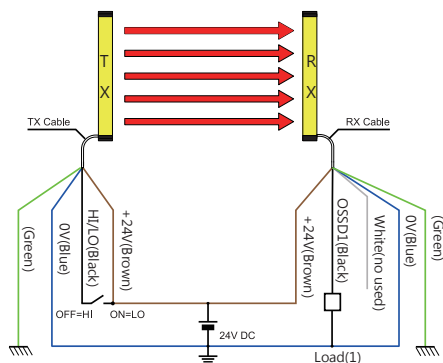

Standard model receiver (1 set of NPN)

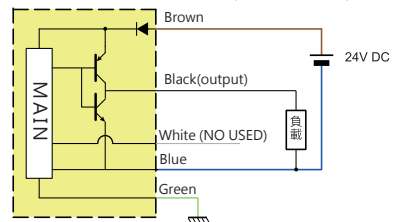

Select model O: has a selectable output, the white line controls the output mode; when the white line is connected to +24V, the black line is the PNP output; when the white line is connected to 0V, the black line is the NPN output.

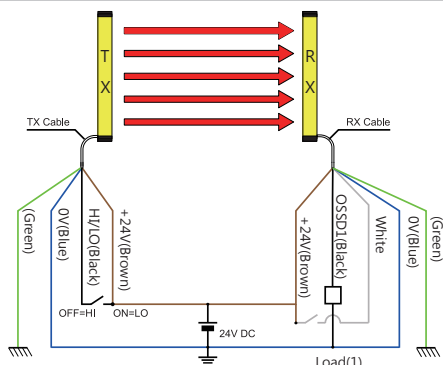

Select model receiver (PNP or NPN)

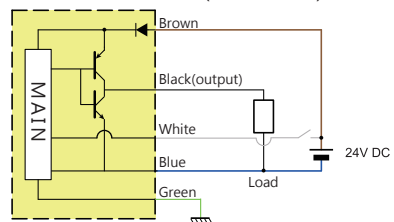

## ND Electric Connection

Standard model: It has a separate NPN output. When the light curtain is normally activated, the black line output is 0V. When blocking, the output is +24V. It can be set to PNP output via white line +24V.

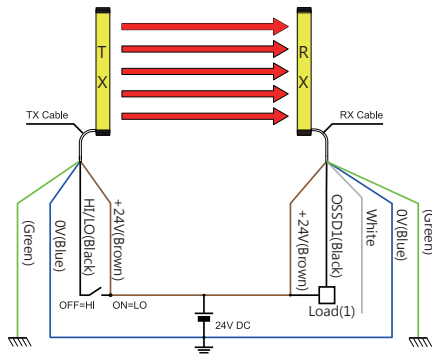

Standard model receiver (1 set of NPN)

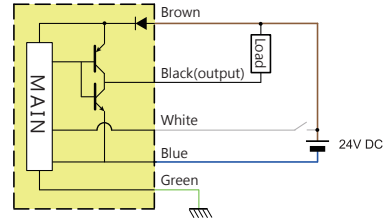

## Accessories

Connector			Part number	
M12 connector	Connector(1) : 180° (standard)	Connector(2) : 90° (select)	N-3m-180	3m (180°)
			N-3m-90	3m (90°)
			N-5m-180	5m (180°)
			N-5m-90	5m (90°)
			N-10m-180	10m (180°)
			N-10m-90	10m (90°)

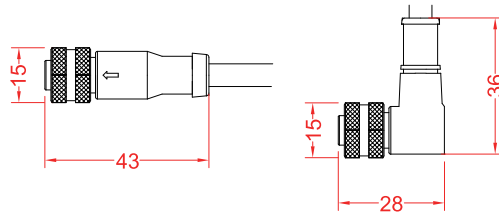

## Braccket

Omnidirectional braccket	Cylindrical braccket	Side type braccket
--------------------------	----------------------	--------------------

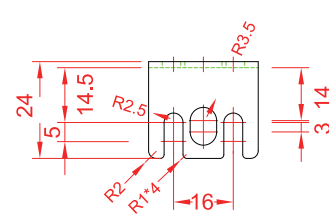
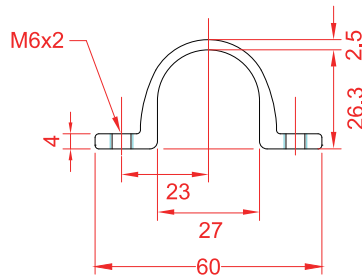
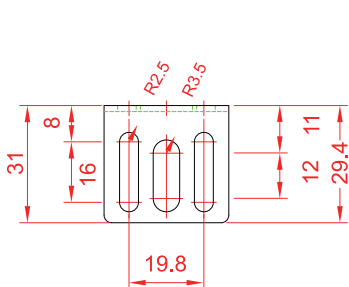
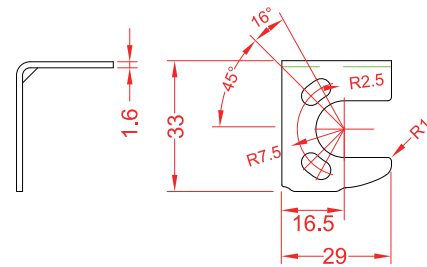
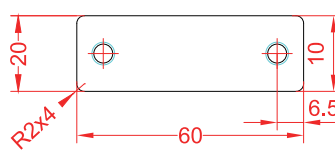
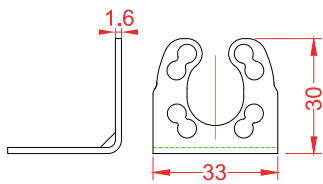

# F series Thin Area sensor

## Applications

- Injection molding machine
- Packing Line Orientation Control
- Object sensing
- Automation industry sensing
- Parking equipment sensing
- Part picking detection
- Assembly line direction control

## Introduction

F series area sensing light curtain, price concessions, stable quality, variety of types, to meet customer needs, is the most suitable for regional use in the detection, protection, inspection and other diversified sensing. Instruction LVD requirements, with CE marking.



## Property

- Various type, 25mm(Unextendable) , 10mm , 20mm , 40mm.
- Detection zone:100mm ~ 940mm.
- Highly-Visible Indicator light.
- IP62.
- Provide NPN or PNP selection.
- Installation and calibration easy.
- Quality and stability, price concessions.

## General Specifications

Beam axis pitch	25mm	10mm	20mm	40mm
Detection zone	100mm	100mm ~ 760mm	140mm ~ 940mm	120mm ~ 920mm
Operating distance	0.3m to 3m (5m)			
Reaction time	20msec (It does not include relay switch time)			
Classification	CE LVD ; No safety certification (do not use in dangerous equipment)			
Power supply	24VDC ± 20%			
Power consumption	Basic 40mA ; 8mA more for each axis, up to 400mA			
Output mode	One set of outputs (NPN); model plus P (PNP output)			
Frequency	FREQ A or FREQ B			
Indicator light	Flashing or steady			
Appearance	Aluminum ; Silver anode treatment(standard) ; Aluminum ; Orange anode treatment(select)			
Connector	Direct output(Single hole fixing) for C type ; M8 connector for T type			
Ambient temperature	0°C to +50°C			
Enclosure rating	IP65			

### FB1-5 series Detection Capability 30mm

Beam axis pitch : 25mm Standard Operating distance 0.3m to 3m  
L type Operating distance 1m to 5m

Model	Beams	Detection Zone (K)(mm)	Overall Length (B)(mm)	Install Length (C)(mm)	Assembly Length (D)(mm)
FB1-5C	5	100	130	140	140

### FB2 series Detection Capability 25mm

Beam axis pitch : 20mm Standard Operating distance 0.3m to 3m  
L type Operating distance 1m to 5m

Model	Beams	Detection Zone (K)(mm)	Overall Length (B)(mm)	Install Length (C)(mm)	Assembly Length (D)(mm)
FB2-8C	8	140	180	190	190
FB2-12C	12	220	260	270	270
FB2-16C	16	300	340	350	350
FB2-20C	20	380	420	430	430
FB2-24C	24	460	500	510	510
FB2-28C	28	540	580	590	590
FB2-32C	32	620	660	670	670
FB2-36C	36	700	740	750	750
FB2-40C	40	780	820	830	830
FB2-44C	44	860	900	910	910
FB2-48C	48	940	980	990	990

### FB3 series Detection Capability 45mm

Beam axis pitch : 40mm Standard Operating distance 0.3m to 3m  
L type Operating distance 1m to 5m

Model	Beams	Detection Zone (K)(mm)	Overall Length (B)(mm)	Install Length (C)(mm)	Assembly Length (D)(mm)
FB3-4C	4	120	180	190	190
FB3-6C	6	200	260	270	270
FB3-8C	8	280	340	350	350
FB3-10C	10	360	420	430	430
FB3-12C	12	440	500	510	510
FB3-14C	14	520	580	590	590
FB3-16C	16	600	660	670	670
FB3-18C	18	680	740	750	750
FB3-20C	20	760	820	830	830
FB3-22C	22	840	900	910	910
FB3-24C	24	920	980	990	990

### FB1 series Detection Capability 15mm

Beam axis pitch : 10mm Standard Operating distance 0.3m to 3m  
L type Operating distance 1m to 5m

Model	Beams	Detection Zone (K)(mm)	Overall Length (B)(mm)	Install Length (C)(mm)	Assembly Length (D)(mm)
FB1-11C	11	100	130	140	140
FB1-22C	22	210	240	250	250
FB1-33C	33	320	350	360	360
FB1-44C	44	430	460	470	470
FB1-55C	55	540	570	580	580
FB1-66C	66	650	680	690	690
FB1-77C	77	760	790	800	800

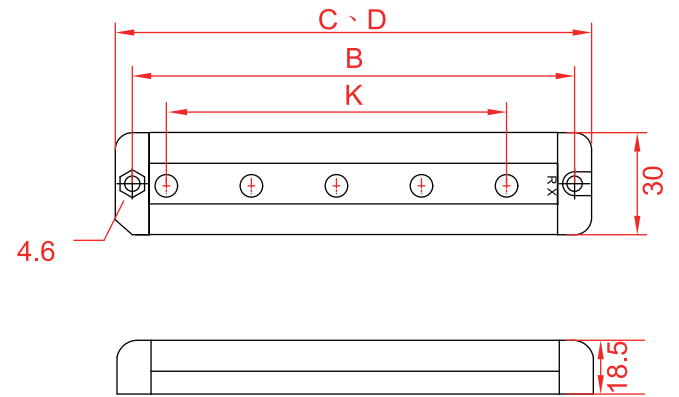

C type (standard type)  
Direct output, Single screw hole fixing

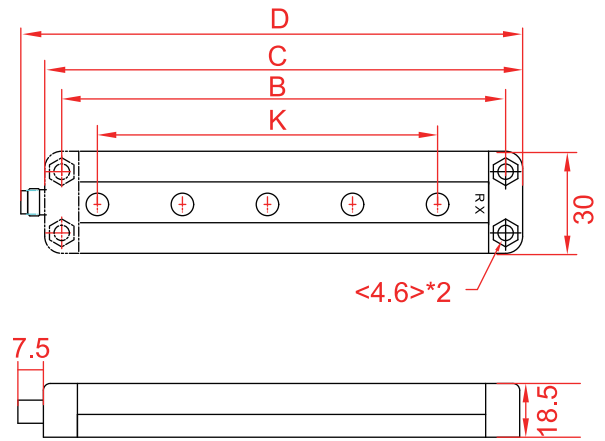

T type  
M8 connector, Double screw hole fixing

The assembly length of the T type is 7.5mm more than the C type.

Customized service description of F series :

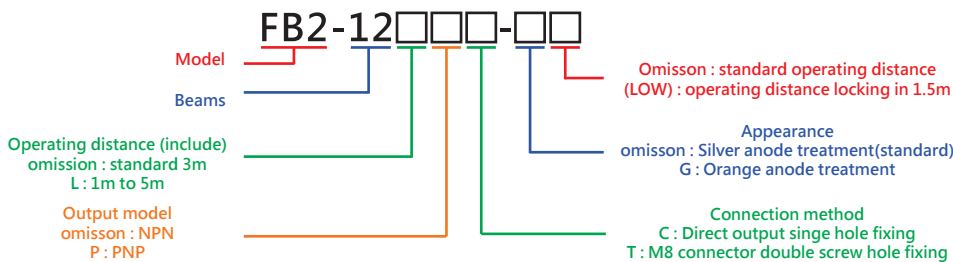

※ SMARTSCAN provide customized services.  
Please connect with our sales.



## Electric Connection

### NPN Output

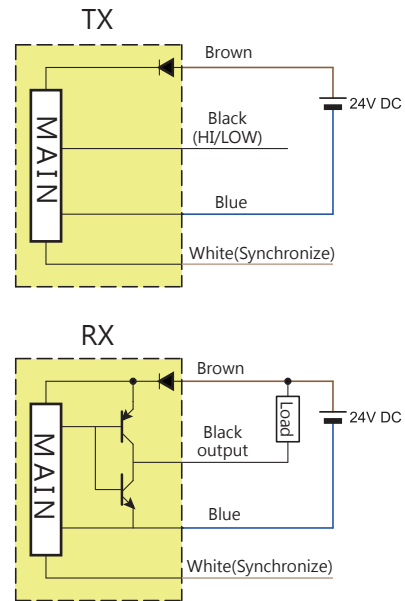
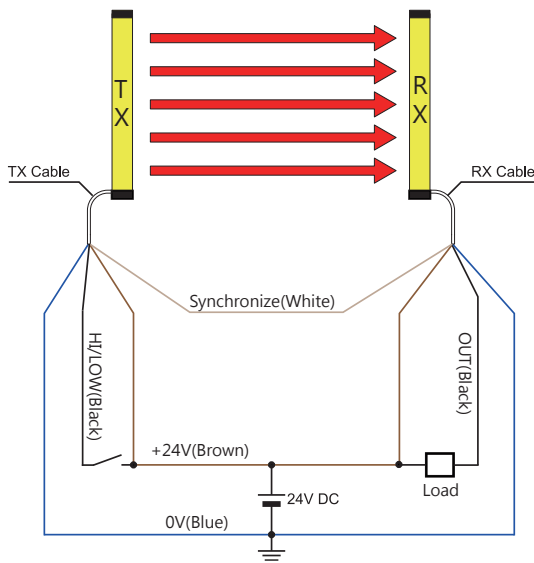

### PNP Output

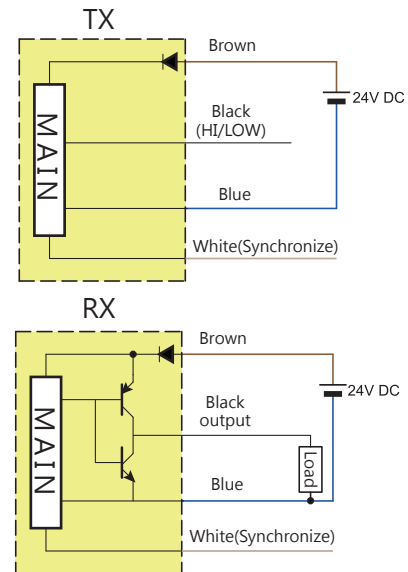
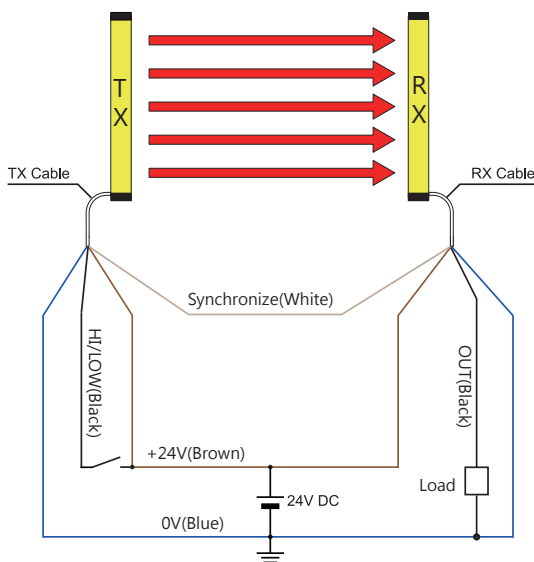

## Detection characteristics

Parallel movement characteristics

Vertical direction

horizontal direction

Vertical direction



horizontal direction

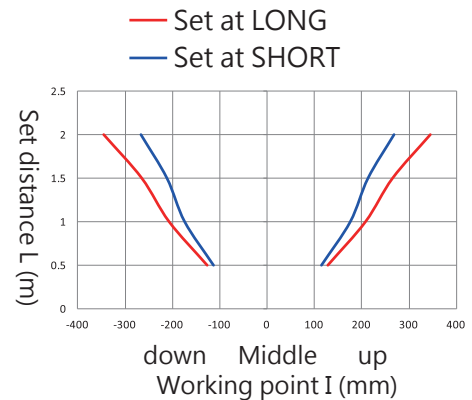
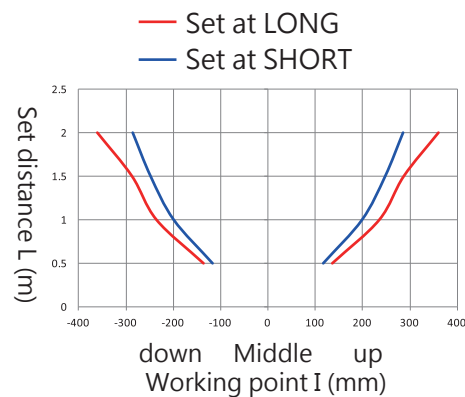
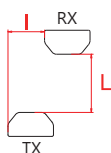

# F Thin Area sensor

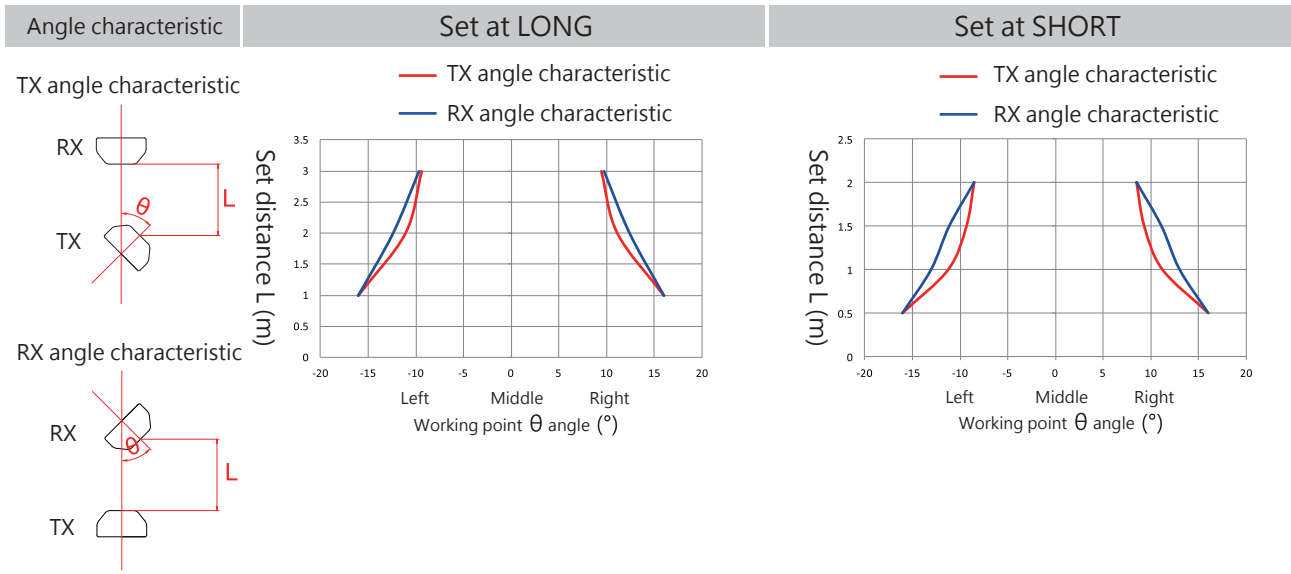

## Highly- Visible Indicator light

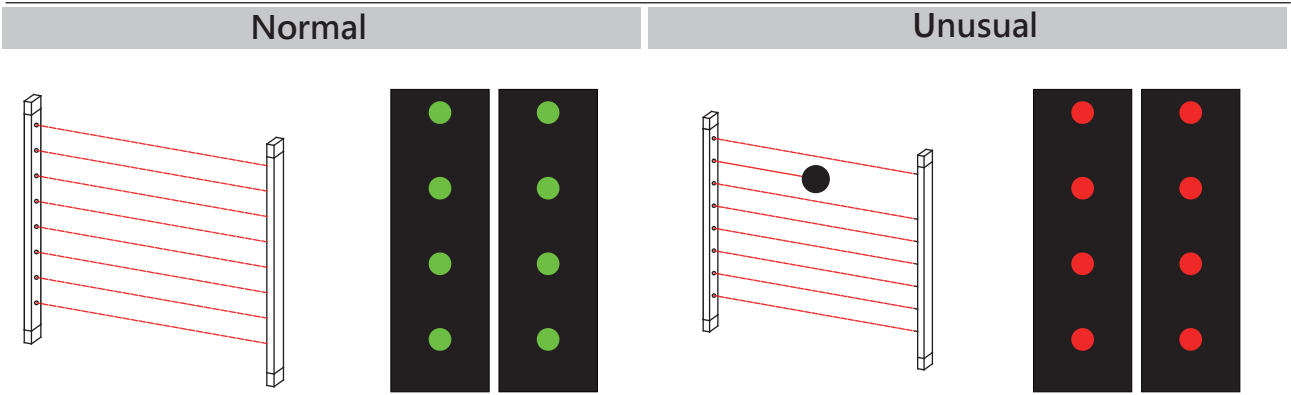

# M series

## Thin Area sensor

### Applications

- Injection molding machine
- Packing Line Orientation Control
- Object sensing
- Automation industry sensing
- Parking equipment sensing
- Part picking detection
- Assembly line direction control

### Introduction

M series area sensing light curtain, price concessions, stable quality, variety of types, to meet customer needs, is the most suitable for regional use in the detection, protection, inspection and other diversified sensing. Instruction LVD requirements, with CE marking.



### Property

- Various type, 25mm(Unextendable) , 10mm , 20mm , 40mm.
- Detection zone:100mm ~ 940mm.
- Highly-Visible Indicator light(only MA series).
- Two frequency options(FREQ A and FREQ B)(only MA series).
- Provide NPN or PNP selection.
- Installation and calibration easy.
- Quality and stability, price concessions.

### General Specifications

Beam axis pitch	25mm	10mm	20mm	40mm
Detection zone	100mm	100mm ~ 540mm	140mm ~ 940mm	120mm ~ 920mm
Operating distance	0.3m to 3m (5m)			
Reaction time	20msec (It does not include relay switch time)			
Classification	CE LVD ; No safety certification (do not use in dangerous equipment)			
Power supply	24VDC ± 20%			
Power consumption	Basic 40mA ; 8mA more for each axis, up to 400mA			
Output mode	One set can be set to NPN or PNP(24V 20mA ; 0V 40mA)			
Frequency	FREQ A(standard) or FREQ B(Select)			
Indicator light	Flashing or steady			
Appearance	Aluminum ; Silver anode treatment(standard) ; Aluminum ; Orange anode treatment(select)			
Connector	Direct output(Single hole fixing) for C type ; M8 connector for T type			
Ambient temperature	0°C to +50°C			
Enclosure rating	IP62			

### MA1-5 series Detection Capability 30mm

Beam axis pitch : 25mm Standard Operating distance 0.5m to 3m

Model	Beams	Detection Zone (K)(mm)	Overall Length (B)(mm)	Install Length (C)(mm)
MA1-5	5	100	130	140

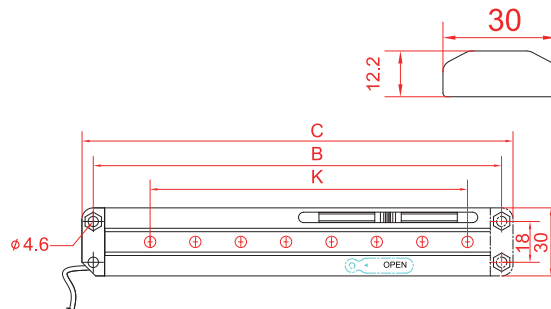

**Standard type**  
Direct output ,double screw hole fixing

### MA2 series Detection Capability 25mm

Beam axis pitch : 20mm Standard Operating distance 0.5m to 3m

Model	Beams	Detection Zone (K)(mm)	Overall Length (B)(mm)	Install Length (C)(mm)
MA2-8	8	140	180	190
MA2-12	12	220	260	270
MA2-16	16	300	340	350
MA2-20	20	380	420	430
MA2-24	24	460	500	510
MA2-28	28	540	580	590
MA2-32	32	620	660	670
MA2-36	36	700	740	750
MA2-40	40	780	820	830
MA2-44	44	860	900	910
MA2-48	48	940	980	990

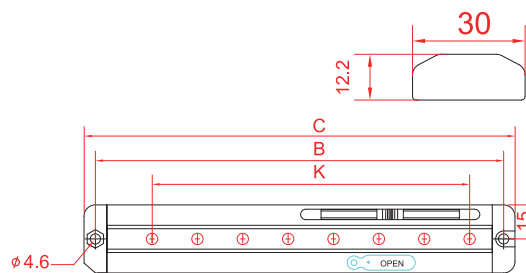

**C type**  
Direct output ,Single screw hole fixing

### MA3 series Detection Capability 45mm

Beam axis pitch : 40mm Standard Operating distance 0.5m to 3m

Model	Beams	Detection Zone (K)(mm)	Overall Length (B)(mm)	Install Length (C)(mm)
MA3-4	4	120	180	190
MA3-6	6	200	260	270
MA3-8	8	280	340	350
MA3-10	10	360	420	430
MA3-12	12	440	500	510
MA3-14	14	520	580	590
MA3-16	16	600	660	670
MA3-18	18	680	740	750
MA3-20	20	760	820	830
MA3-22	22	840	900	910
MA3-24	24	920	980	990

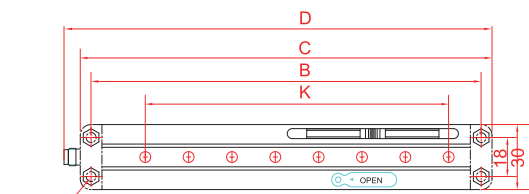

**T type**  
M8 connector ,Double screw hole fixing



The assembly length of the T type is 7.5mm more than the C type.

#### Customized service description of M series :

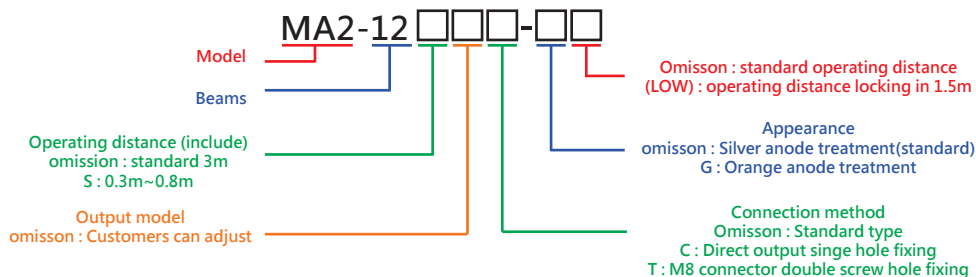

※ SMARTSCAN provide customized services.  
Please connect with our sales.

# MA series Set up

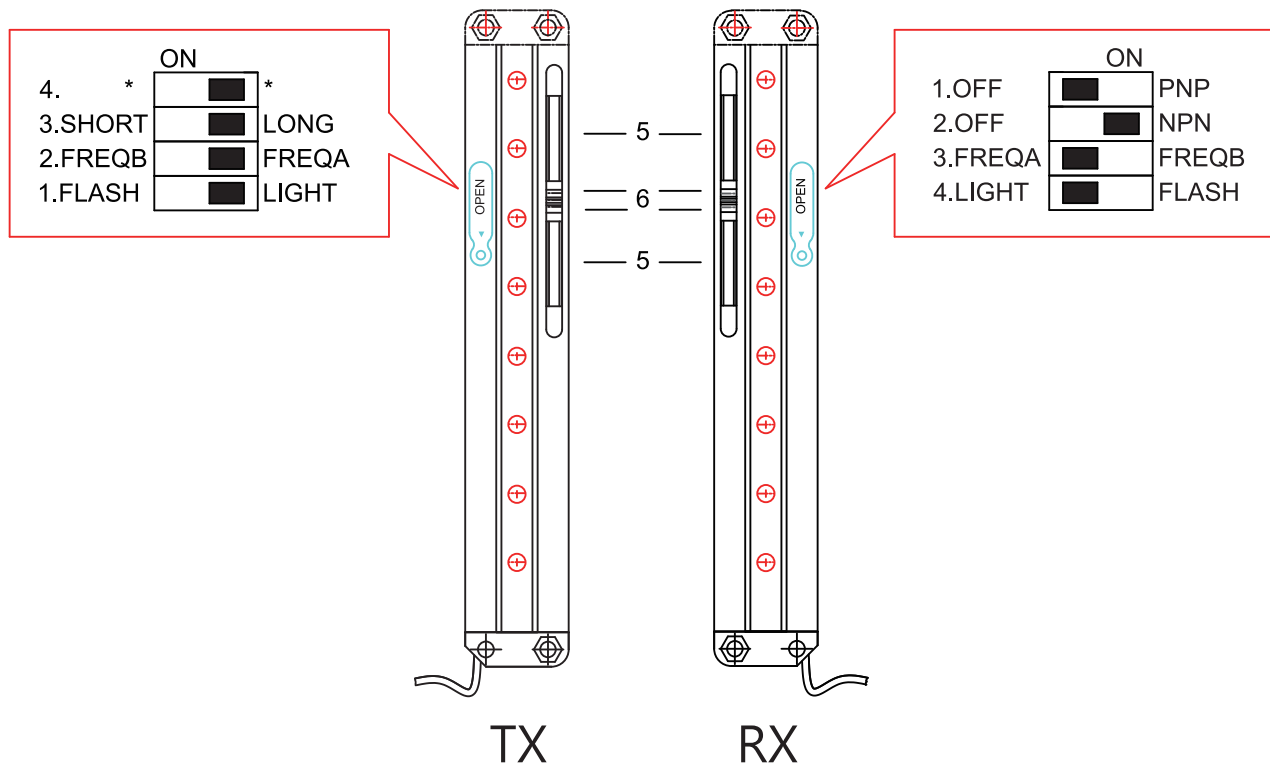

		Description	Function	
TX	1	Indicator light mode	Flash	Hengliang
	2	Frequency (*1)	FREQ B (*1)	FREQ A (*1)
	3	Operating distance	Short (1.5m)	Long (standard)
	4	NO USED		
RX	1	PNP Output	OFF	ON ; PNP output (*2)
	2	NPN Output	OFF	ON ; NPN output (*3)
	3	Frequency (*1)	FREQ A (*1)	FREQ B (*1)
	4	Indicator light mode	Flash	Hengliang
5	Indicator light (orange)	Can choose to flash model or hengliang model		
6	Indicator light	TX:Yellow light ; RX:Normal=green , abnormal=red		

**\*1:Frequency must be consistent**

**\*2,\*3:NPN and PNP can only choose one**

## MB1-5 series Detection Capability 30mm

Beam axis pitch : 25mm Standard Operating distance 0.5m to 3m

Model	Beams	Detection Zone (K)(mm)	Overall Length (B)(mm)	Install Length (C)(mm)
MB1-5	5	100	130	140

(NO Setting function and indicator light)

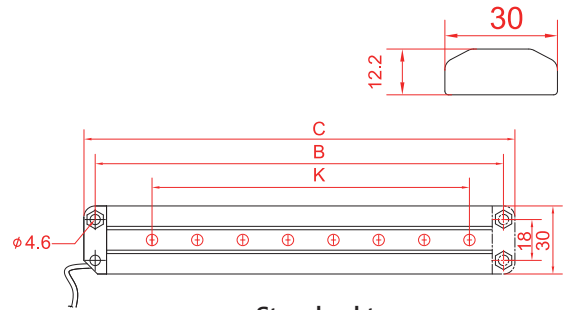

Standard type

Direct output ,double screw hole fixing  
(NO Setting function and indicator light)

## MB2 series Detection Capability 25mm

Beam axis pitch : 20mm Standard Operating distance 0.5m to 3m

Model	Beams	Detection Zone (K)(mm)	Overall Length (B)(mm)	Install Length (C)(mm)
MB2-8	8	140	180	190
MB2-12	12	220	260	270
MB2-16	16	300	340	350
MB2-20	20	380	420	430
MB2-24	24	460	500	510
MB2-28	28	540	580	590
MB2-32	32	620	660	670
MB2-36	36	700	740	750
MB2-40	40	780	820	830
MB2-44	44	860	900	910
MB2-48	48	940	980	990

(NO Setting function and indicator light)

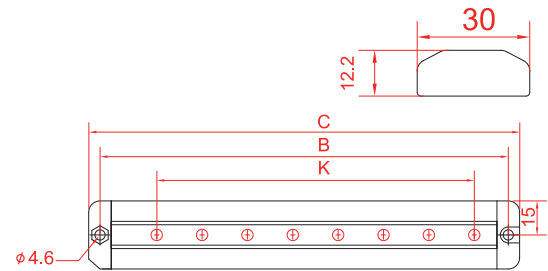

C type

Direct output ,Single screw hole fixing  
(NO Setting function and indicator light)

## MB3 series Detection Capability 45mm

Beam axis pitch : 40mm Standard Operating distance 0.5m to 3m

Model	Beams	Detection Zone (K)(mm)	Overall Length (B)(mm)	Install Length (C)(mm)
MB3-4	4	120	180	190
MB3-6	6	200	260	270
MB3-8	8	280	340	350
MB3-10	10	360	420	430
MB3-12	12	440	500	510
MB3-14	14	520	580	590
MB3-16	16	600	660	670
MB3-18	18	680	740	750
MB3-20	20	760	820	830
MB3-22	22	840	900	910
MB3-24	24	920	980	990

(NO Setting function and indicator light)

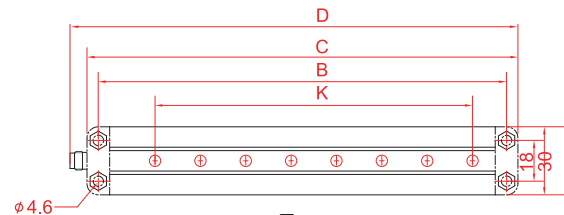

T type

M8 connector ,Double screw hole fixing  
(NO Setting function and indicator light)



### Customized service description of M series :

(NO Setting function and indicator light)

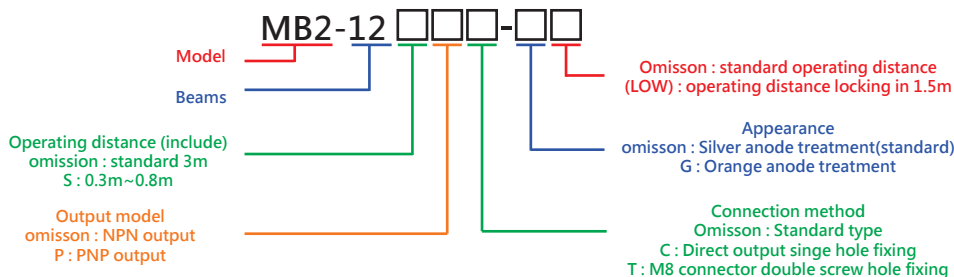

※ SMARTSCAN provide customized services.  
Please connect with our sales.

## Electric Connection

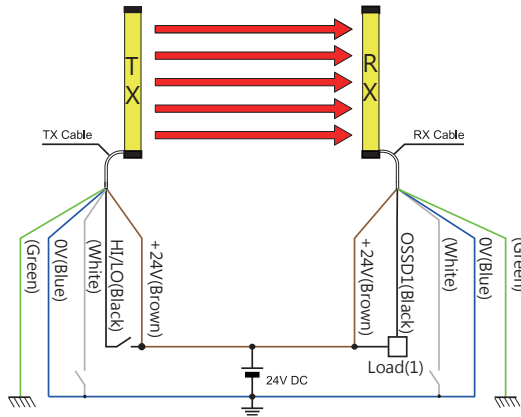

Standard RX (NPN output)

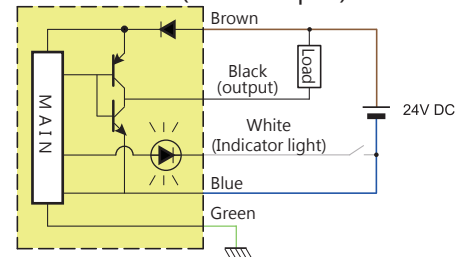

TX black line connect to +24V transmit power is short distance.

TX RX white line connect to 0V that Indicator light will light on.

※Because the line sync is used, the white line needs to be docked, so there is no indicator function.

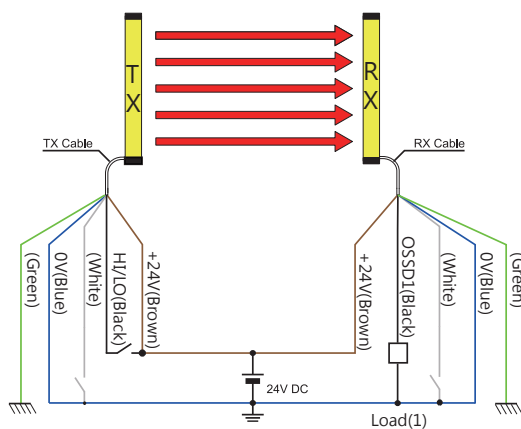

Select RX (PNP output)

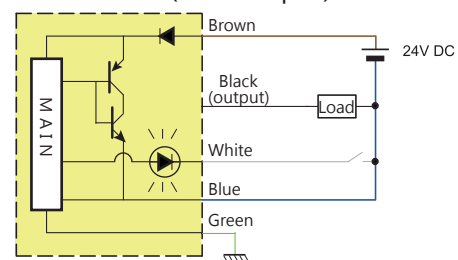

TX black line connect to +24V transmit power is short distance.

TX RX white line connect to 0V that Indicator light will light on.

※Because the line sync is used, the white line needs to be docked, so there is no indicator function.

## Detection characteristics

MA1 series

MA2 series

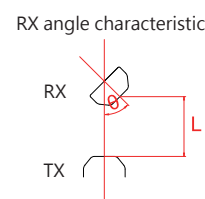
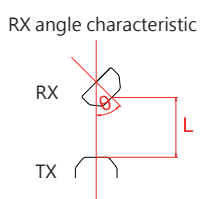
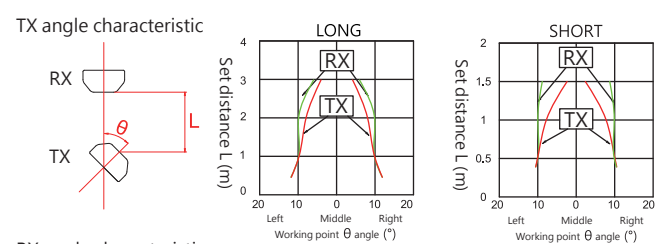
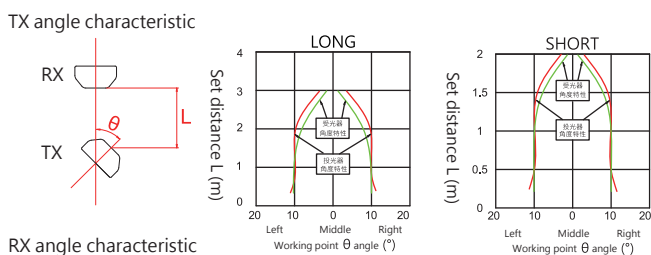
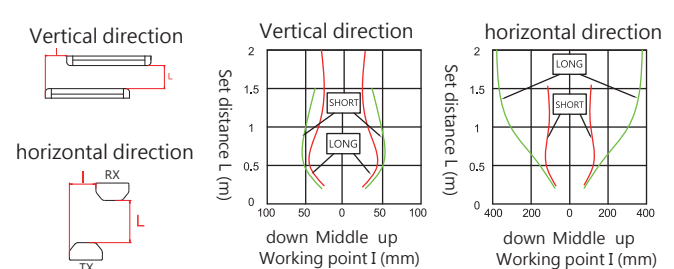
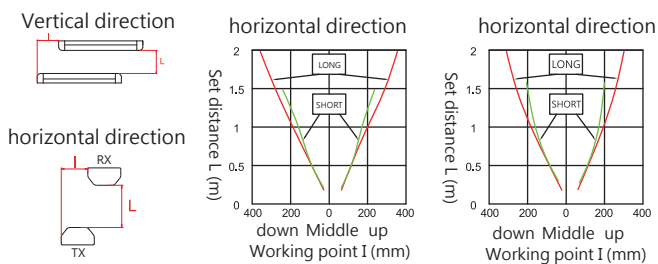

# MS series

## Thin Area sensor

### Applications

- Injection molding machine
- Packing Line Orientation Control
- Object sensing
- Automation industry sensing
- Parking equipment sensing
- Part picking detection
- Assembly line direction control

### Introduction

MS series area sensing light curtain, price concessions, stable quality, variety of types, to meet customer needs, is the most suitable for regional use in the detection, protection, inspection and other diversified sensing. Instruction LVD requirements, with CE marking.



### Property

- Various type, 25mm(Unextendable) , 10mm , 20mm , 40mm.
- Detection zone:100mm ~ 940mm.
- Highly-Visible Indicator light.
- IP-62.
- Provide NPN or PNP selection.
- Installation and calibration easy.
- Quality and stability, price concessions.
- With line synchronization,excellent anti-interference ability.

### General Specifications

Beam axis pitch	25mm	20mm	40mm
Beams	5	8-48	4-24
Detection zone	100mm	140mm ~ 940mm	120mm ~ 920mm
Operating distance	0.3m to 1.5m		
Reaction time	20msec (It does not include relay switch time)		
Classification	CE LVD ; No safety certification (do not use in dangerous equipment)		
Power supply	24VDC $\pm$ 20%		
Power consumption	Basic 40mA ; 8mA more for each axis, up to 400mA		
Output mode	One set can be set to NPN or PNP(24V 20mA ; 0V 40mA)		
Appearance	Aluminum ; Silver anode treatment(standard) ; Aluminum ; Orange anode treatment(select)		
Connector	Direct output(Single hole fixing) for C type		
Ambient temperature	0°C to +50°C		
Enclosure rating	IP62		



### MSB1-5 series Detection Capability 30mm

Beam axis pitch : 25mm  
 Operating distance LOW 0.5m to 0.8m ; HI 0.5 to 1.5m

Model	Beams	Detection Zone (K)(mm)	Overall Length (B)(mm)	Install Length (C) (mm)
MSB1-5	5	100	130	140

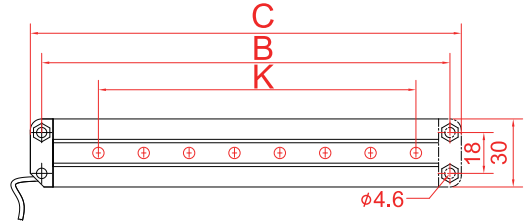

### MSB2 series Detection Capability 25mm

Beam axis pitch : 20mm  
 Operating distance LOW 0.5m to 0.8m ; HI 0.5 to 1.5m

Model	Beams	Detection Zone (K)(mm)	Overall Length (B)(mm)	Install Length (C) (mm)
MSB2-8	8	140	180	190
MSB2-12	12	220	260	270
MSB2-16	16	300	340	350
MSB2-20	20	380	420	430
MSB2-24	24	460	500	510
MSB2-28	28	540	580	590
MSB2-32	32	620	660	670
MSB2-36	36	700	740	750
MSB2-40	40	780	820	830
MSB2-44	44	860	900	910
MSB2-48	48	940	980	990

Standard type  
 Dirc output ,double screw hole fixing

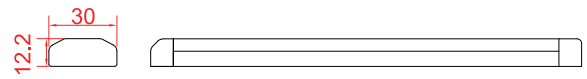

### MSB3 series Detection Capability 45mm

Beam axis pitch : 40mm  
 Operating distance LOW 0.5m to 0.8m ; HI 0.5 to 1.5m

Model	Beams	Detection Zone (K)(mm)	Overall Length (B)(mm)	Install Length (C) (mm)
MSB3-4	4	120	180	190
MSB3-6	6	200	260	270
MSB3-8	8	280	340	350
MSB3-10	10	360	420	430
MSB3-12	12	440	500	510
MSB3-14	14	520	580	590
MSB3-16	16	600	660	670
MSB3-18	18	680	740	750
MSB3-20	20	760	820	830
MSB3-22	22	840	900	910
MSB3-24	24	920	980	990

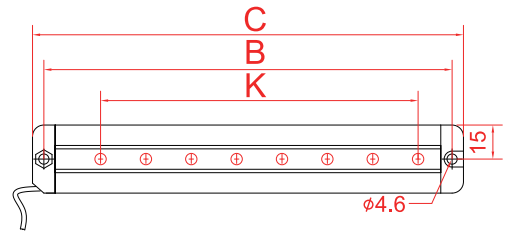

C type  
 Dirc output ,Single screw hole fixing

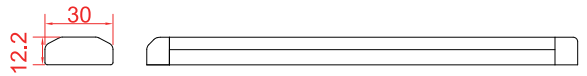

Customized service description of MS series :

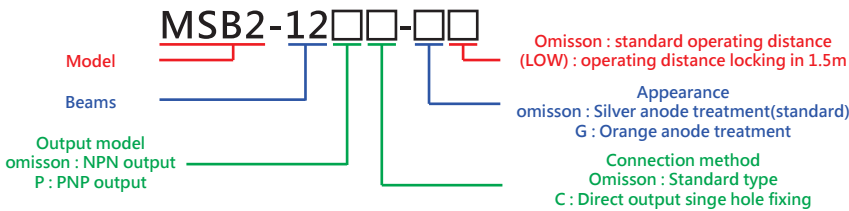

※ SMARTSCAN provide customized services.  
 Please connect with our sales.

Electric Connection

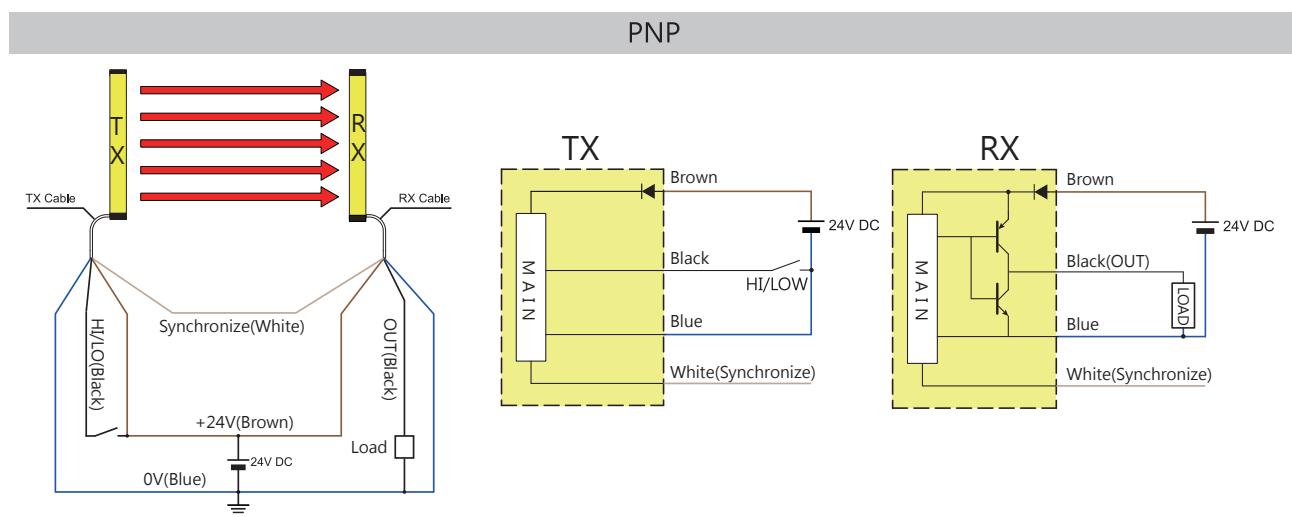
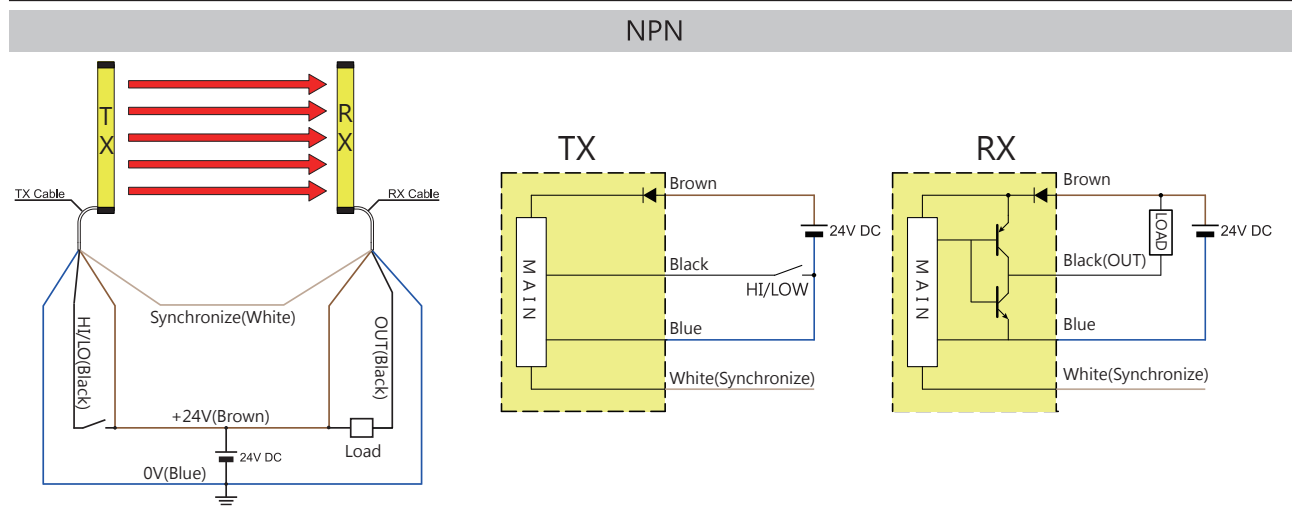

Detection characteristics

Parallel movement characteristics	Vertical direction	horizontal direction
-----------------------------------	--------------------	----------------------

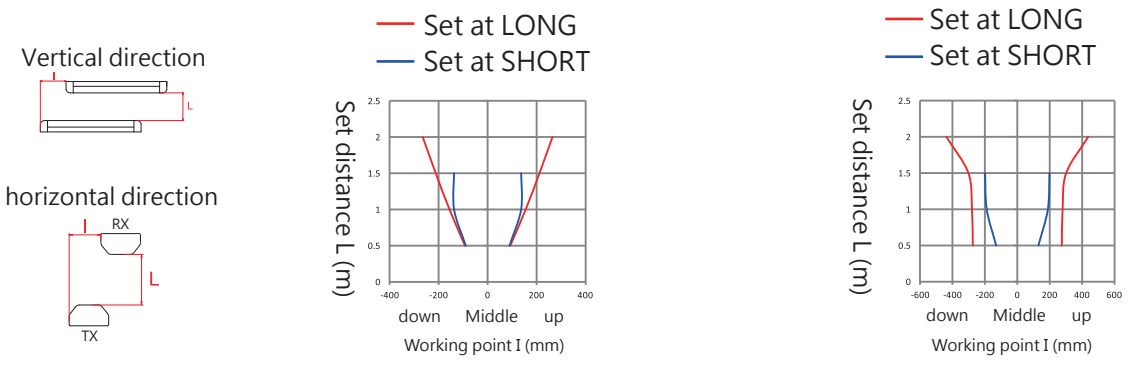

Angle characteristic	Set at LONG	Set at SHORT
----------------------	-------------	--------------

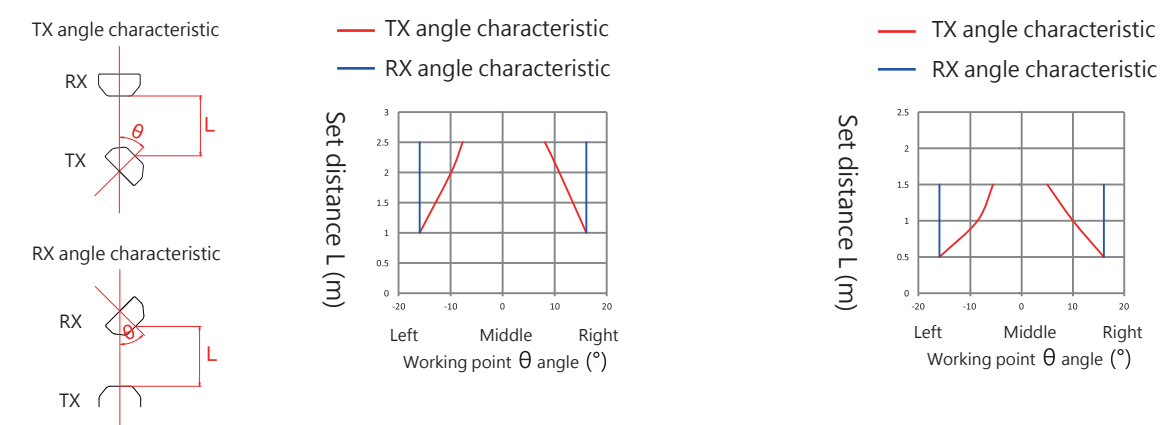

# LX series

## Thin Area sensor

### Applications

- Injection molding machine
- Packing Line Orientation Control
- Object sensing
- Automation industry sensing
- Parking equipment sensing
- Part picking detection
- Assembly line direction control

### Introduction

LX series area sensing light curtain, price concessions, stable quality, variety of types, to meet customer needs, is the most suitable for regional use in the detection, protection, inspection and other diversified sensing. Instruction LVD requirements, with CE marking.

The LX series is side mounting and has a thickness of only 12.4mm.

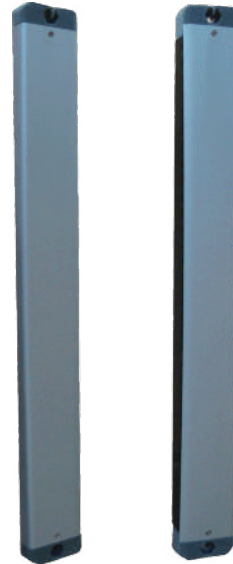

### Property

- Various type, 10mm , 20mm , 40mm.
- Detection zone:100mm ~ 940mm.
- Side mounting.
- Two frequency options(FREQ A and FREQ B)
- Provide NPN or PNP selection.
- Installation and calibration easy.
- Quality and stability, price concessions.

### General Specifications

Beam axis pitch	10mm	20mm	40mm
Beams	11~55	8~48	4~24
Detection zone	100mm ~ 540mm	140mm ~ 940mm	120mm ~ 920mm
Operating distance	0.3m to 3m		
Reaction time	20msec (It does not include relay switch time)		
Classification	CE LVD ; No safety certification (do not use in dangerous equipment)		
Power supply	24VDC ± 20%		
Power consumption	Basic 40mA ; 8mA more for each axis, up to 400mA		
Output mode	One set can be set to NPN or PNP(24V 20mA ; 0V 40mA)		
Frequency	FREQ A(standard) or FREQ B(Select)		
Indicator light	Flashing or steady		
Appearance	Aluminum ; Silver anode treatment(standard)		
Connector	Direct output(Single hole fixing) for C type		
Ambient temperature	0°C to +50°C		
Enclosure rating	IP62		

## LX series

### LX1 C TYPE Detection Capability 15mm

Beam axis pitch : 10mm Standard Operating distance 0.5m to 2.5m

Model	Beams	Detection Zone (K)(mm)	Overall Length (B)(mm)	Install Length (C)(mm)
LX1-11C	11	100	130	140
LX1-22C	22	210	240	250
LX1-33C	33	320	350	360
LX1-44C	44	430	460	470
LX1-55C	55	540	570	580

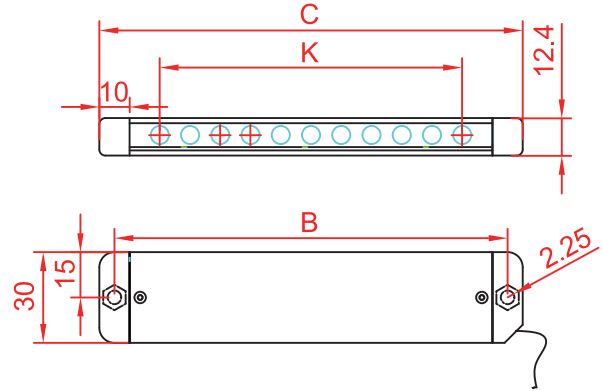

### LX2 C TYPE Detection Capability 30mm

Beam axis pitch : 20mm Standard Operating distance 0.5m to 2.5m

Model	Beams	Detection Zone (K)(mm)	Overall Length (B)(mm)	Install Length (C)(mm)
LX2-8C	8	140	180	190
LX2-12C	12	220	260	260
LX2-16C	16	300	340	340
LX2-20C	20	380	420	430
LX2-24C	24	460	500	510
LX2-28C	28	540	580	590
LX2-32C	32	620	660	670
LX2-36C	36	700	740	750
LX2-40C	40	780	820	830
LX2-44C	44	860	900	910
LX2-48C	48	940	980	990

### LX3 C TYPE Detection Capability 50mm

Beam axis pitch : 40mm Standard Operating distance 0.5m to 3m

Model	Beams	Detection Zone (K)(mm)	Overall Length (B)(mm)	Install Length (C)(mm)
LX3-4C	8	140	180	190
LX3-6C	12	220	260	260
LX3-8C	16	300	340	340
LX3-10C	20	380	420	430
LX3-12C	24	460	500	510
LX3-14C	28	540	580	590
LX3-16C	32	620	660	670
LX3-18C	36	700	740	750
LX3-20C	40	780	820	830
LX3-22C	44	860	900	910
LX3-24C	48	940	980	990

## Electric Connection

### LX1

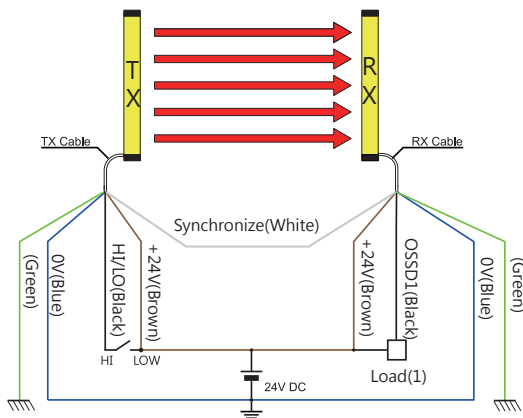

### Standard RX (NPN output)

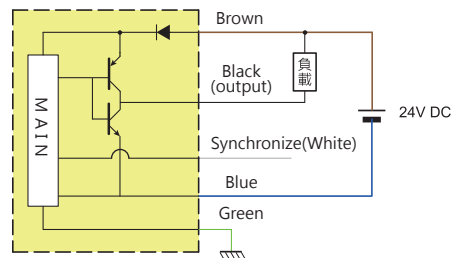

TX black line connect to +24V transmit power is short distance.

TX RX white line is synchronize.

LX2 · LX3

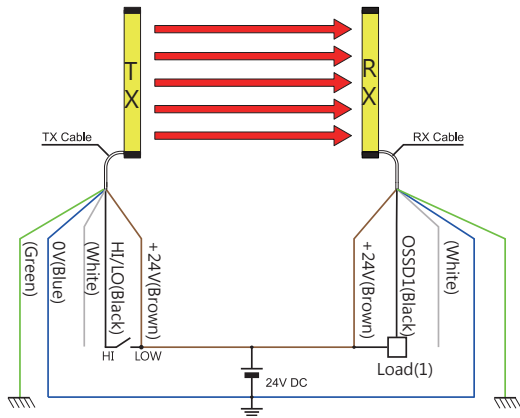

Standard RX (NPN output)

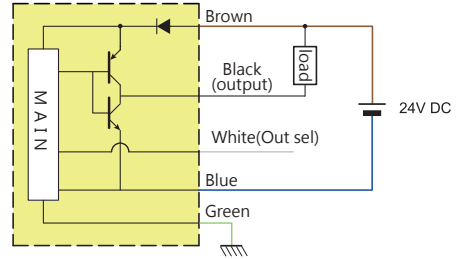

TX black line connect to +24V transmit power is short distance.

When the RX white line is not connected, the black line is the NPN output.

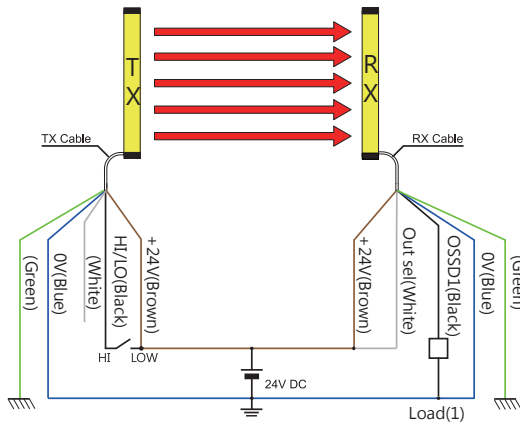

Standard RX (PNP output)

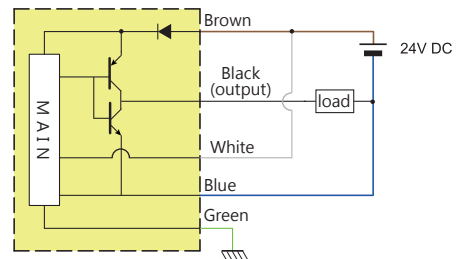

TX black line connect to +24V transmit power is short distance.

When the RX connect to +24V, the black line is the PNP output.

Detection characteristics

Parallel movement characteristics

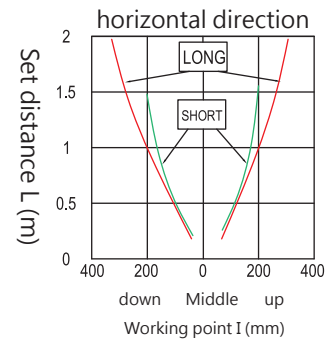
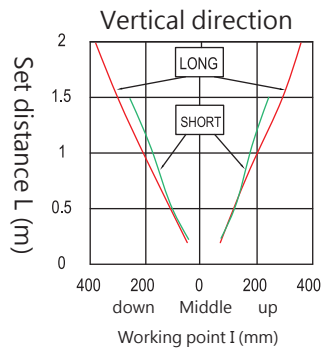
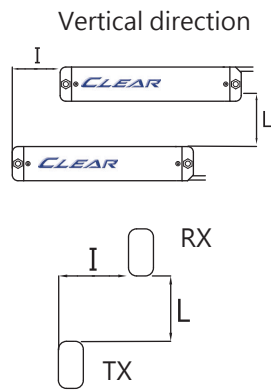

Angle characteristic  
TX angle characteristic

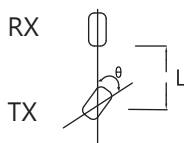

RX angle characteristic

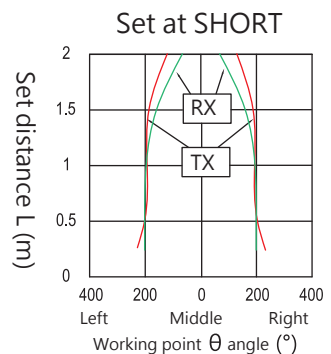
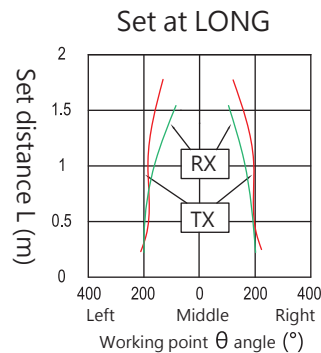
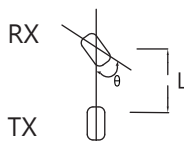

# EX series

## Diffuse reflection mode sensor

### Applications

- One-sided installation saves space
- Object detection
- Customized size



### Introduction

In addition to the traditional light curtain, the EX series is diffuse and reflective, the transmitting(TX) and the receiving(RX) are all on the same side, using the principle of self-light reflection of the object, suitable for the case where only one side can be installed, conforms to the EMC standard, and passes the third-party detection unit. certificate.

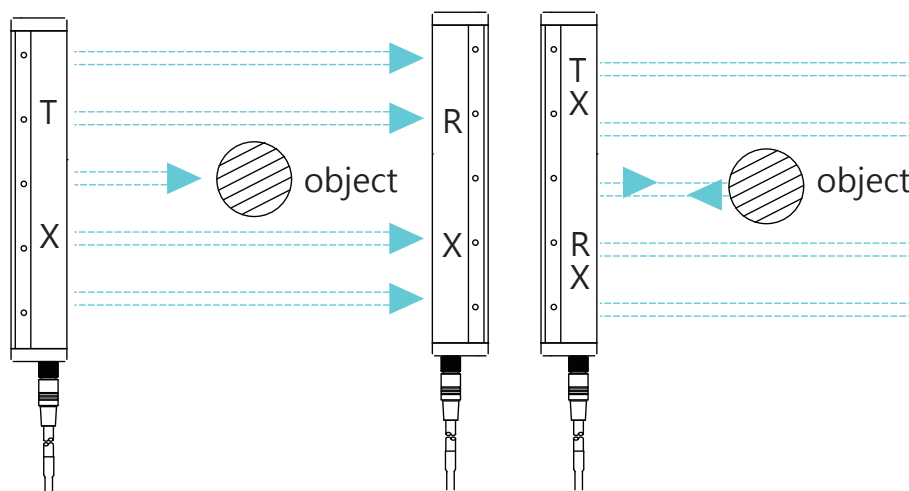

Traditional light curtain

EX series light curtain

### Property

- Beam axis pitch 58mm.
- Detection zone:215mm~customized.
- Provide NPN or PNP selection.
- suitable for the case where only one side can be installed
- Metal structure.

### General Specifications

Beam axis pitch	58mm
Beams	2~Customized
Detection zone	203mm~Customized
Operating distance	0m to 1.5m
Reaction time	Maximum detection reaction time 70msec
Classification	CE LVD ; No safety certification (do not use in dangerous equipment)
Power supply	24VDC ± 20%
Installation method	Reserved space, customized mounting holes
Output mode	One set can be set to NPN or PNP(24V 20mA ; 0V 40mA)
Appearance	Aluminum ; Silver anode treatment(standard)
Connector	M8 connector
Ambient temperature	0°C to +50°C
Enclosure rating	IP54

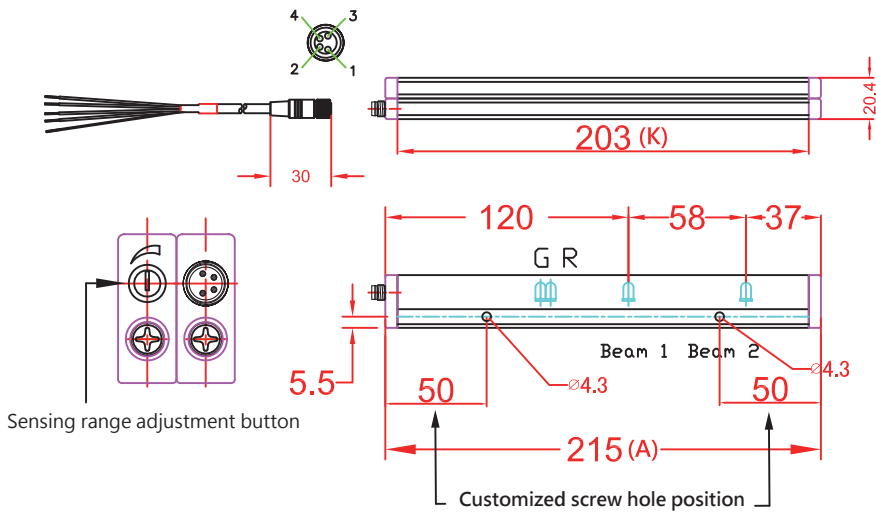

## EX series

Beam axis pitch:58mm EX(Beams)-58-Total length

Model	Beams	Detection Zone (K)(mm)	Overall Length (A)(mm)
EX2-58-215	2	203	215
EX3-58-273	3	261	273
EX4-58-331	4	319	331
EX5-58-389	5	377	389

## Indicator number and wiring method

### Indicator number

There is an LED working indicator light on the TX; there are two LED working indicator lights on the RX.

System status display

Location and color	Status	Means
TX Yellow LED	■ ON	The system is normal; no light means OFF
RX Red LED	■ ON	There is reflection or system abnormality, the system stops outputting or disconnects the signal status.
RX Green LED	■ ON	Normal status

### Output / input and wiring

#### NPN

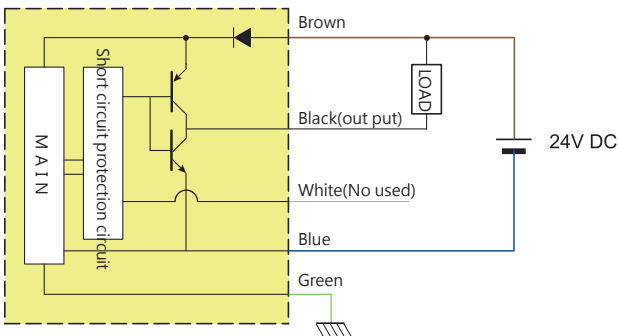

#### PNP

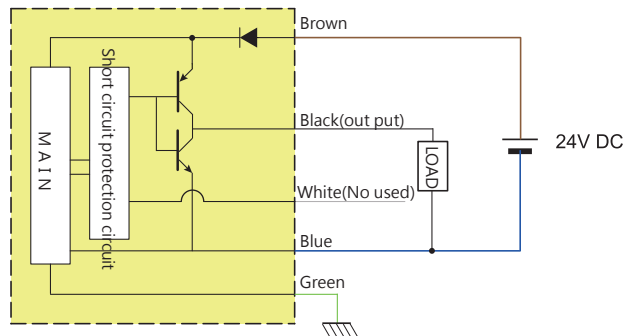

## Accessories

M8 connector ; 3m for standard ; 5m,10m for select.

Model	Description
EX-3M-180	3m cable ; 180°
EX-3M-90	3m cable ; 90°

