



## GDT Series 3-Jaw Concentric Grippers



### Specification

Model	GDT-304	GDT-306	GDT-308	GDT-310	GDT-312	GDT-316	GDT-320	GDT-330
Stroke per jaw (mm)	4	6	8	10	12	16	20	30
Closing force (N)	385	640	1020	1700	2975	5525	6970	13000
Opening force (N)	425	680	1105	1785	3060	5610	7185	13220
Closing/opening Time (s)	0.025/0.025	0.03/0.03	0.05/0.05	0.1/0.1	0.2/0.2	0.25/0.25	0.35/0.35	0.8/0.8
Max. pressure (bar)	6	6	7	7	7	8	8	
Min. pressure (bar)	3	3	3	3	3	3	3	3
Compressed air consumption (cm <sup>3</sup> )	8	20.5	45	110	195	485	850	2300
Weight(kg)	0.23	0.55	0.9	1.62	2.72	5.2	9.7	24.5
Recom. work piece weight(kg)	2	3.2	5	8.3	14.6	27	34.2	64

Model	GDT-308-S	GDT-310-S	GDT-312-S	GDT-316-S	GDT-320-S	GDT-330-S
Stroke per jaw (mm)	4	5	6	8	10	15
Closing force (N)	2210	3740	6460	11900	15430	29030
Opening force (N)	2380	3910	6675	12240	15895	29500
Closing/opening Time (s)	0.05/0.05	0.1/0.1	0.2/0.2	0.25/0.25	0.35/0.35	0.8/0.8
Max. pressure (bar)	7	7	7	7	8	8
Min. pressure (bar)	3	3	3	3	3	3
Compressed air consumption (cm <sup>3</sup> )	45	110	195	485	850	2300
Weight(kg)	0.9	1.62	2.72	5.2	9.7	24.5
Recom. work piece weight(kg)	11	18	32	58	76	142

### GDT-304



#### Standard Accessories



Locating Pins



Centering sleeve



Mounting block

#### Optional Accessories



Spring ejector device



Finger accessories



Magnetic reed switch sensor  
2 wire/NPN/PNP

※This model is not compatible with proximity switch.

## Gripping force

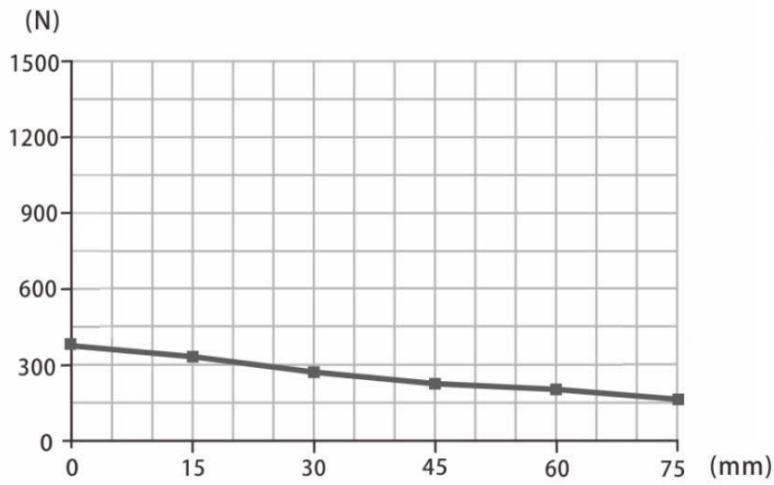

■ GDT-304 Standard type

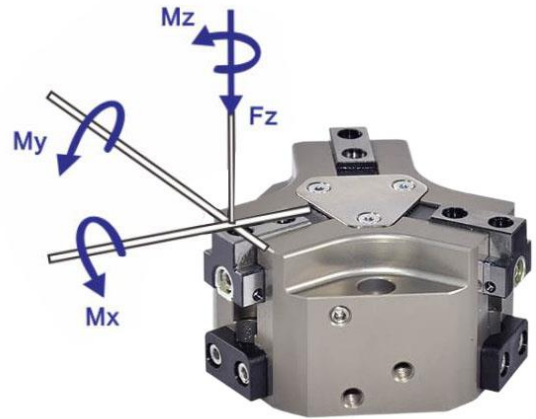

- Mx max. 12.0 Nm
- My max. 12.0 Nm
- Mz max. 6.5 Nm
- Fz max. 560.0 N

## Spring ejectur device Installation diagram

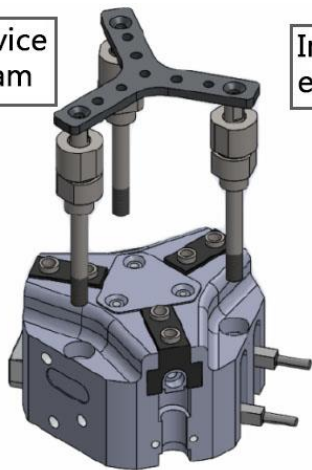

## Installation exploded diagram

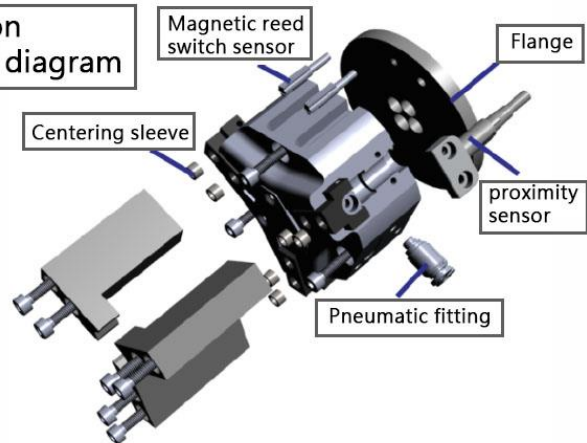

## Specification

Model	GDT-304
Stroke per jaw (mm)	4
Closing force (N)	385
Opening force (N)	425
Closing/opening Time (s)	0.025/0.025
Max. pressure (bar)	6
Min. pressure (bar)	3
Compressed air consumption (cm <sup>3</sup> )	8
Weight(kg)	0.23
Recom. work piece weight(kg)	2

## Dimensions

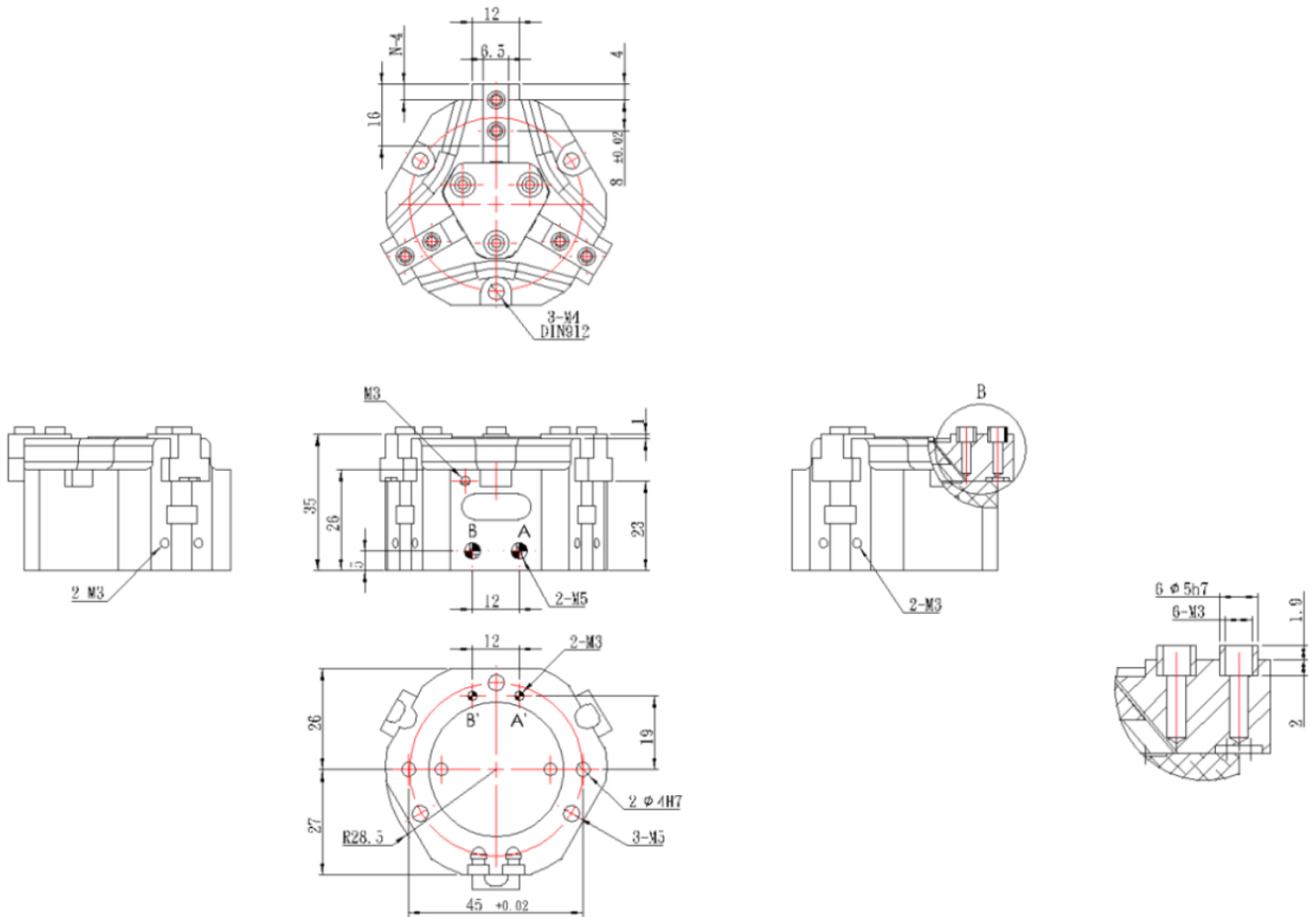

※ This diagram shows the basic dimensions of the main body of the gripper and does not include the dimensions of optional accessories

## GDT-306



Standard Accessories



Optional Accessories

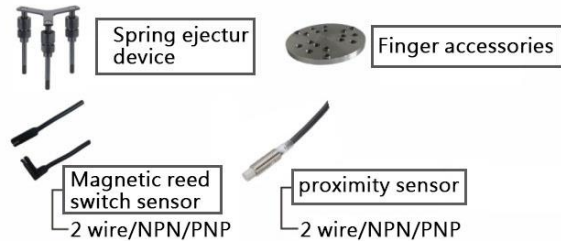

### Gripping force

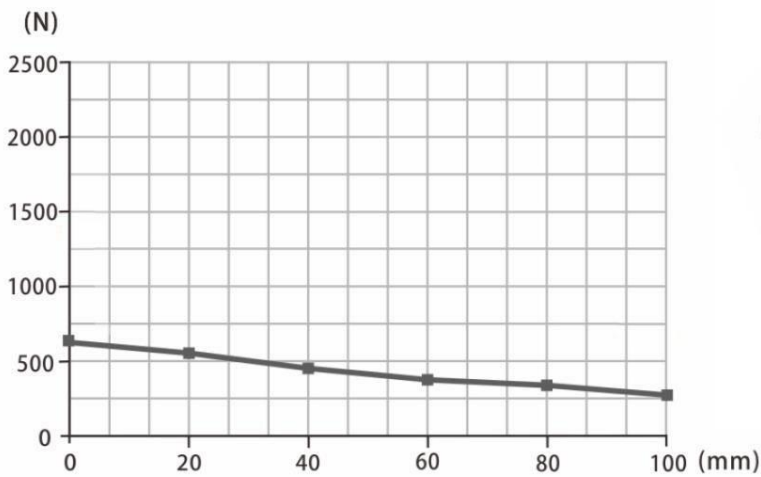

■ GDT-306 Standard type

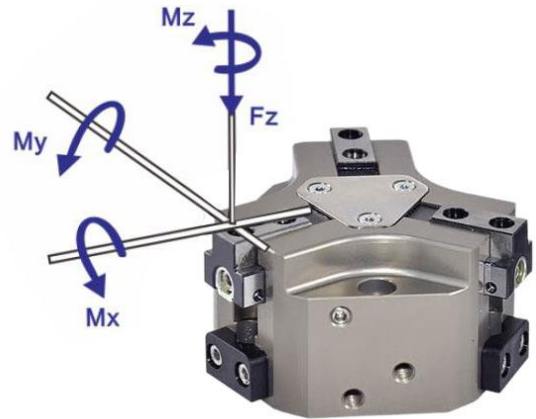

- Mx max. 40.0 Nm
- My max. 36.0 Nm
- Mz max. 28.0 Nm
- Fz max. 960.0 N

### Spring ejector device Installation diagram

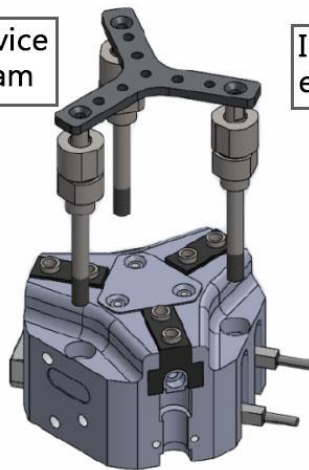

### Installation exploded diagram

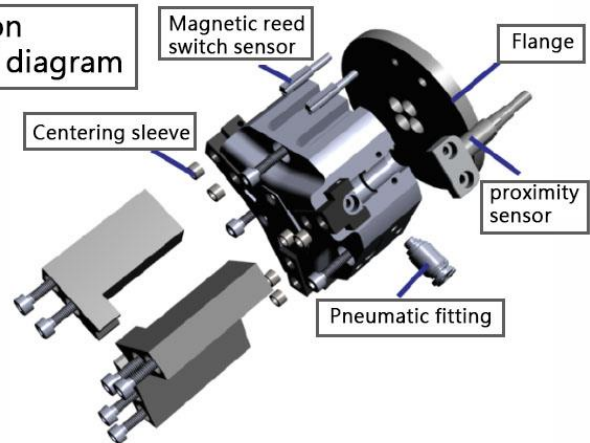



## Specification

Model	GDT-306
Stroke per jaw (mm)	6
Closing force (N)	640
Opening force (N)	680
Closing/opening Time (s)	0.03/0.03
Max. pressure (bar)	6
Min. pressure (bar)	3
Compressed air consumption (cm <sup>3</sup> )	20.5
Weight(kg)	0.55
Recom. work piece weight(kg)	3.2

## Dimensions

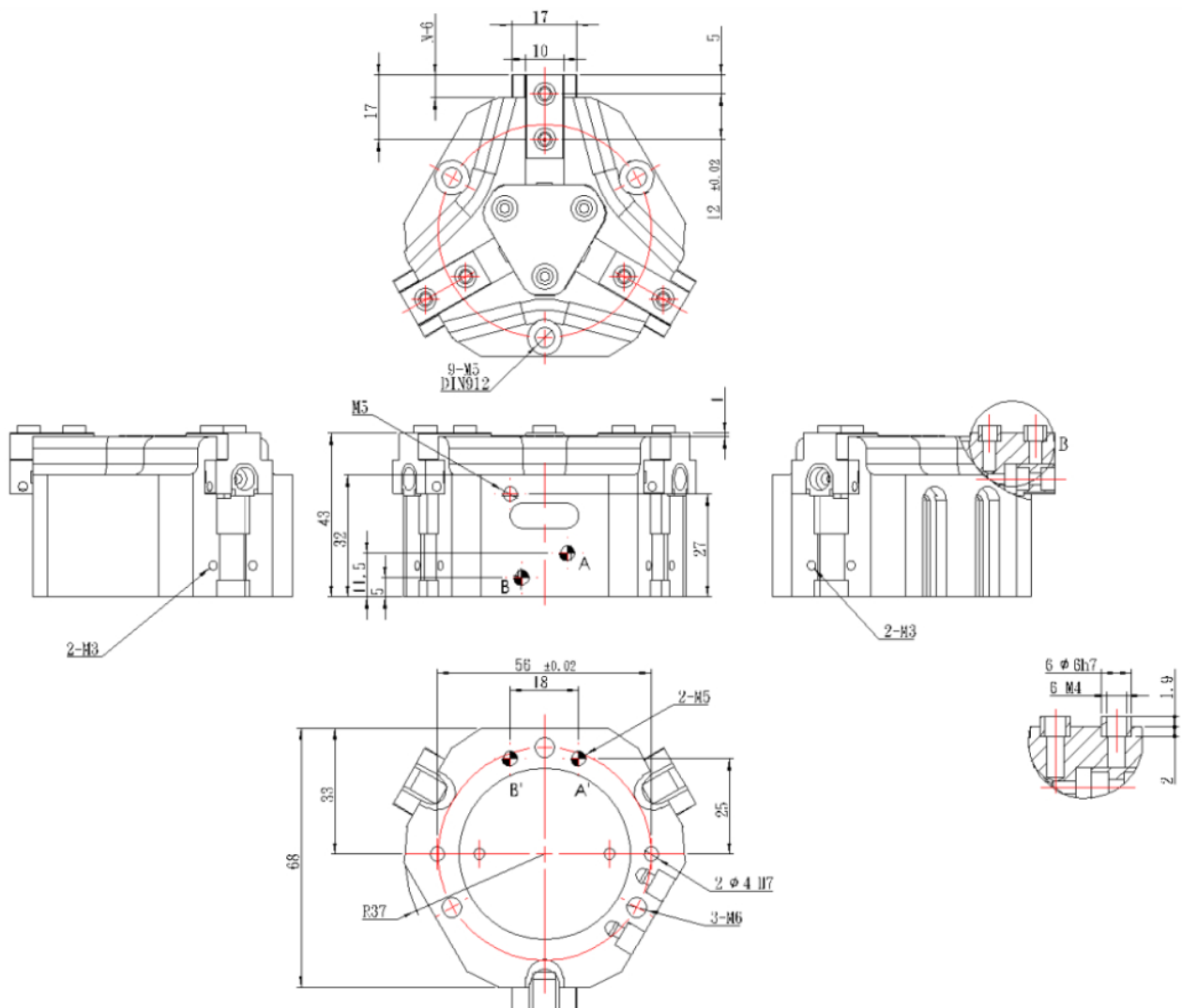

※ This diagram shows the basic dimensions of the main body of the gripper and does not include the dimensions of optional accessories

## GDT-308 / GDT-308-S



Standard Accessories



Optional Accessories

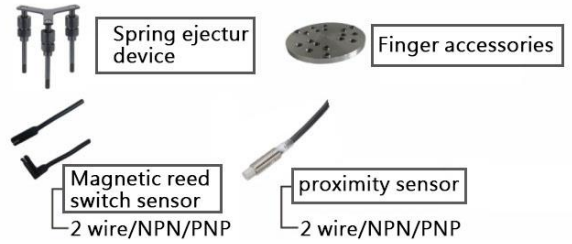

### Gripping force

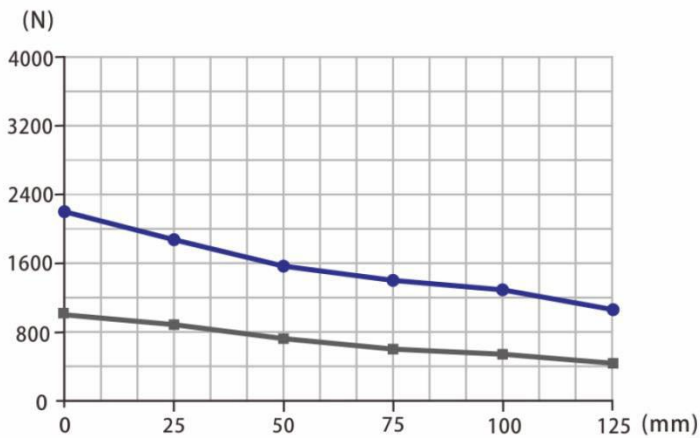

● GDT-308-S Heavy-duty type  
■ GDT-308 Standard type

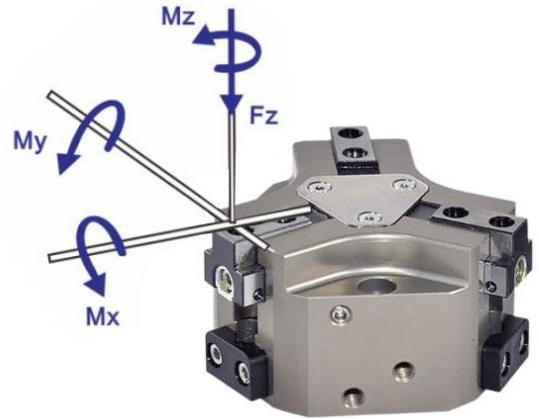

■ Mx max. 65.0 Nm  
■ My max. 48.0 Nm  
■ Mz max. 40.0 Nm  
■ Fz max. 1440.0 N

### Spring ejector device Installation diagram

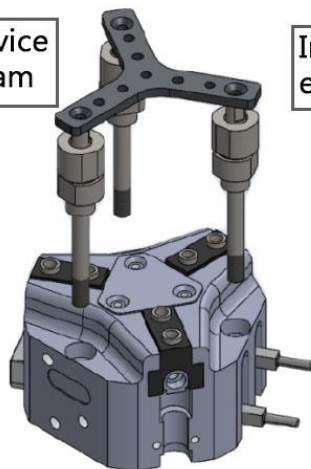

### Installation exploded diagram

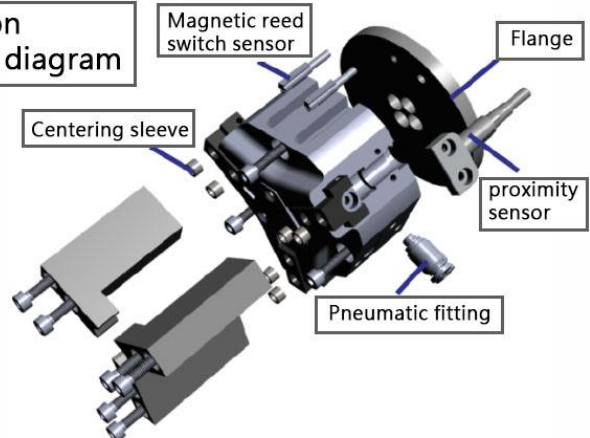



## Specification

Model	GDT-308	GDT-308-S
Stroke per jaw (mm)	8	4
Closing force (N)	1020	2210
Opening force (N)	1105	2380
Closing/opening Time (s)	0.05/0.05	0.05/0.05
Max. pressure (bar)	7	7
Min. pressure (bar)	3	3
Compressed air consumption (cm <sup>3</sup> )	45	45
Weight(kg)	0.9	0.9
Recom. work piece weight(kg)	5	11

## Dimensions

Standard type 8  
Heavy-duty type 4

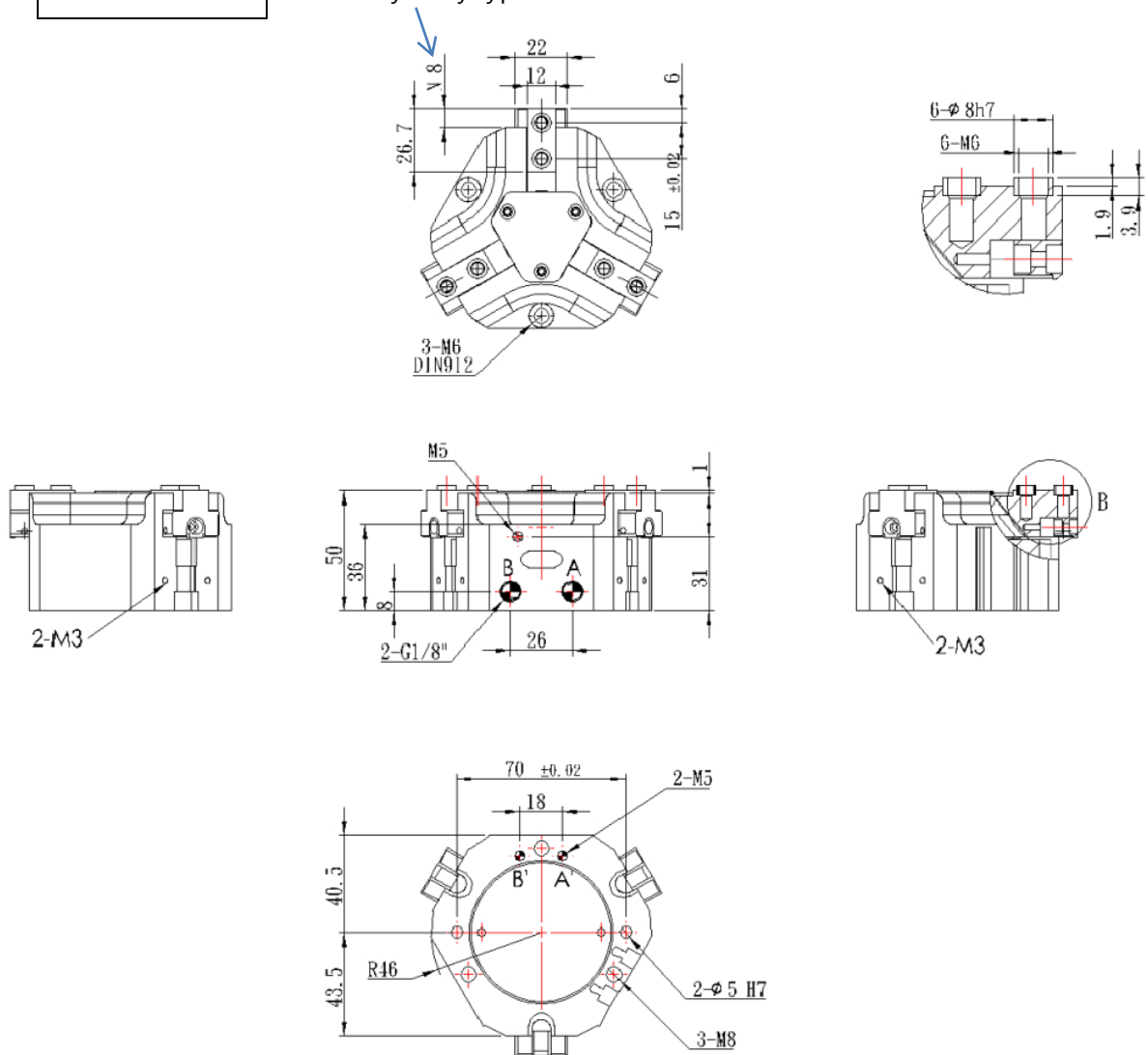

※ This diagram shows the basic dimensions of the main body of the gripper and does not include the dimensions of optional accessories

## GDT-310 / GDT-310-S



Standard Accessories



Optional Accessories

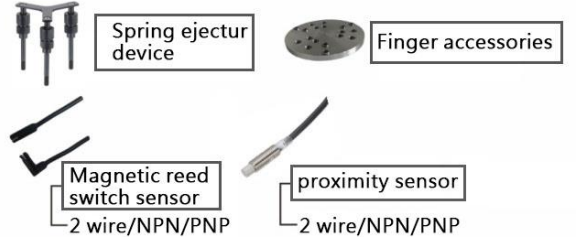

### Gripping force

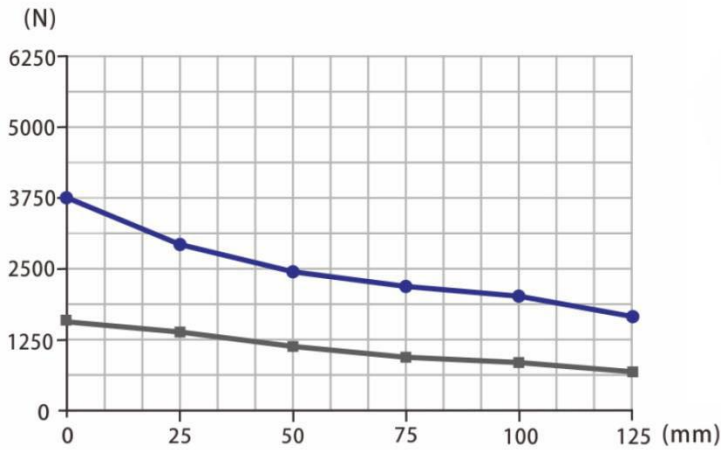

● GDT-310-S Heavy-duty type  
■ GDT-310 Standard type

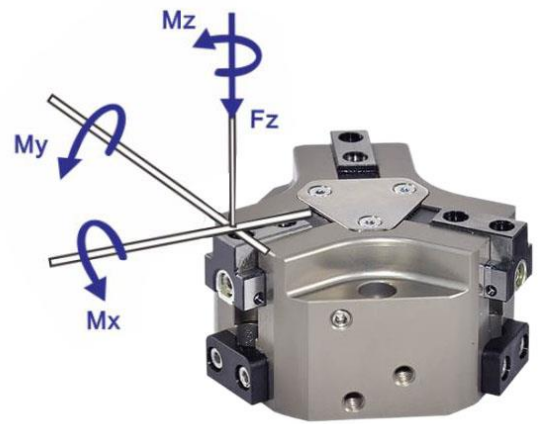

■ Mx max. 80.0 Nm  
■ My max. 72.0 Nm  
■ Mz max. 60.0 Nm  
■ Fz max. 2000.0 N

### Spring ejector device Installation diagram

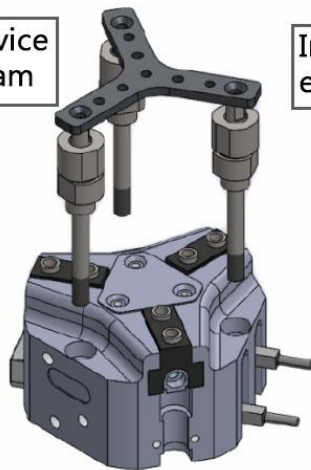

### Installation exploded diagram

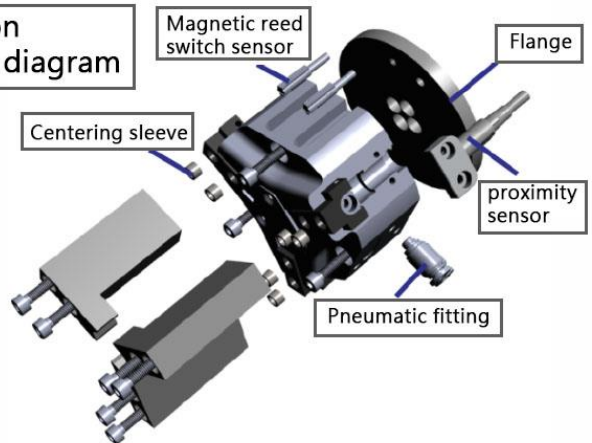





## Specification

Model	GDT-310	GDT-310-S
Stroke per jaw (mm)	10	5
Closing force (N)	1700	3740
Opening force (N)	1785	3910
Closing/opening Time (s)	0.1/0.1	0.1/0.1
Max. pressure (bar)	7	7
Min. pressure (bar)	3	3
Compressed air consumption (cm <sup>3</sup> )	110	110
Weight(kg)	1.62	1.62
Recom. work piece weight(kg)	8.3	18

## Dimensions

Standard type 10  
Heavy-duty type 5

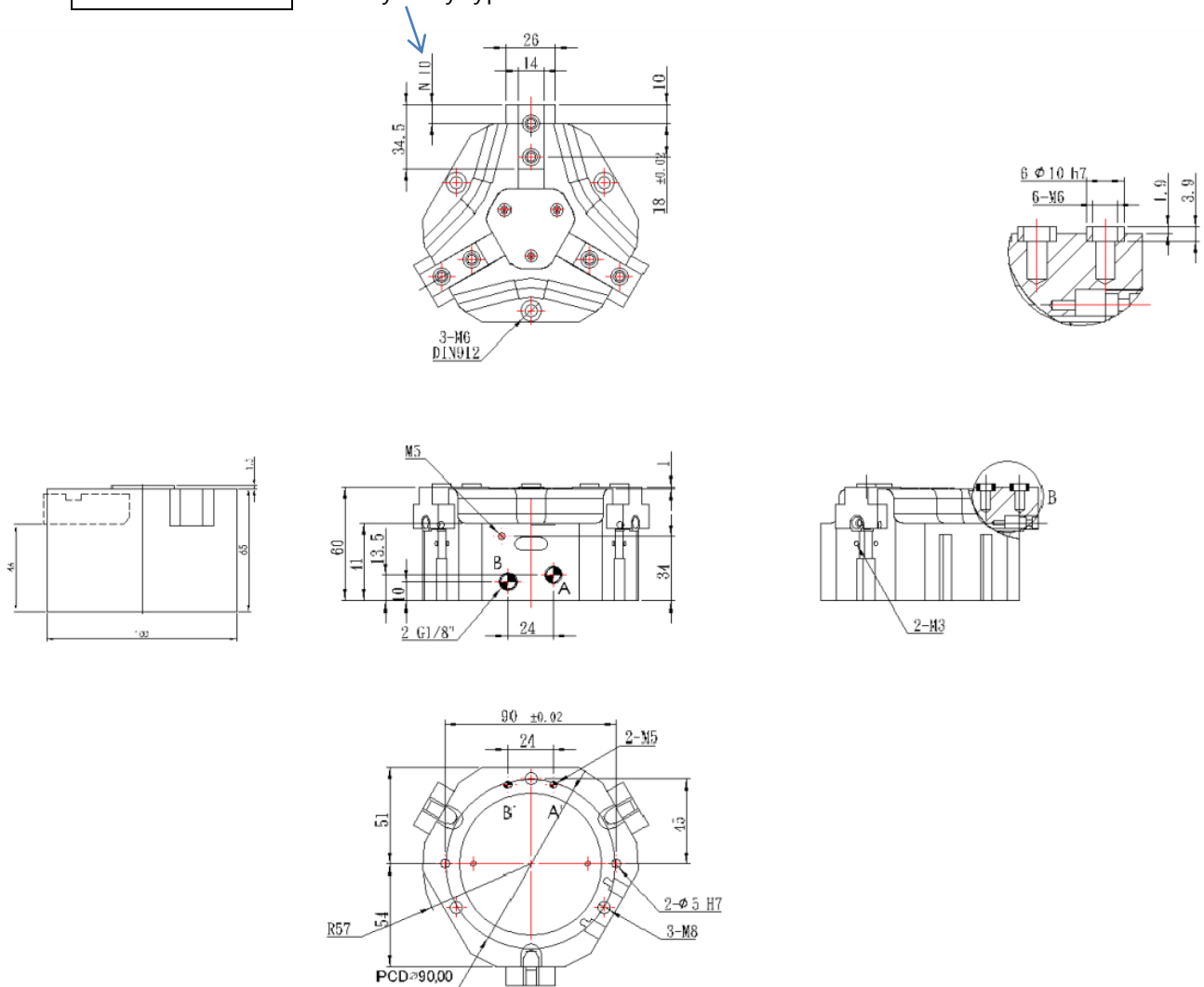

※ This diagram shows the basic dimensions of the main body of the gripper and does not include the dimensions of optional accessories



## GDT-312 / GDT-312-S



Standard Accessories



Optional Accessories

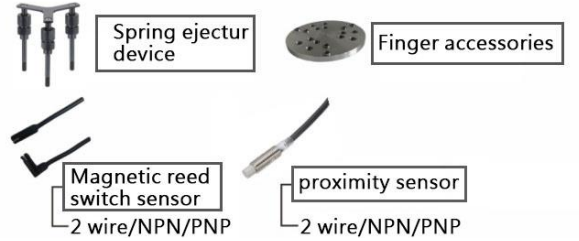

Gripping force

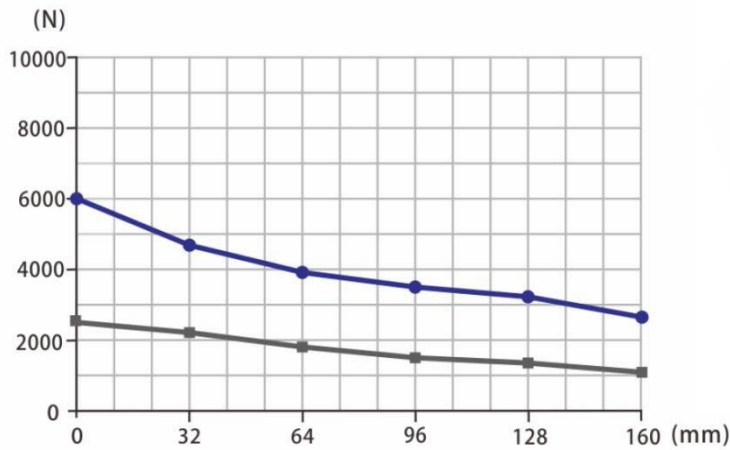

- GDT-312-S Heavy-duty type
- GDT-312 Standard type

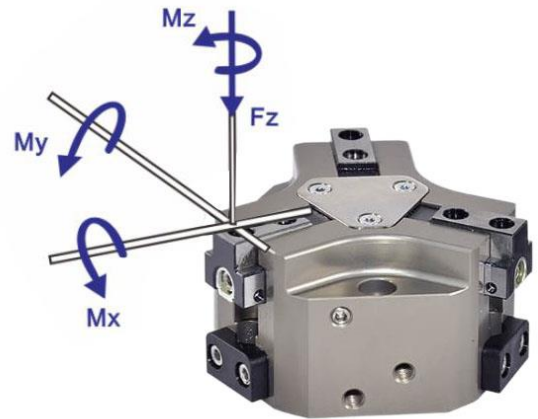

- Mx max. 95.0 Nm
- My max. 96.0 Nm
- Mz max. 80.0 Nm
- Fz max. 2560.0 N

Spring ejector device Installation diagram

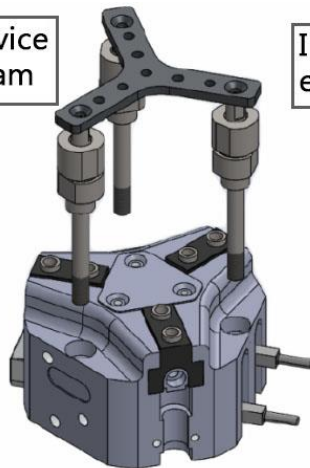

Installation exploded diagram

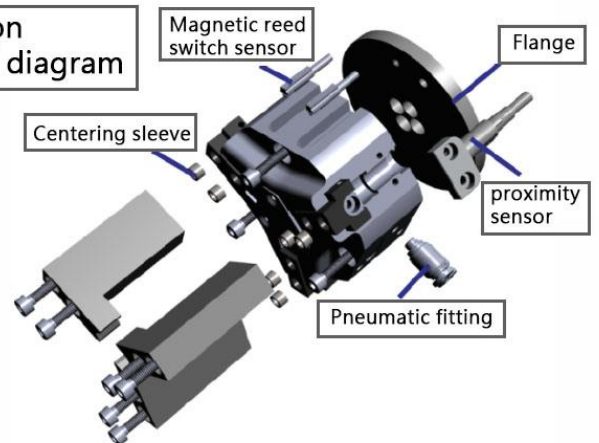



## Specification

Model	GDT-312	GDT-312-S
Stroke per jaw (mm)	12	6
Closing force (N)	2975	6460
Opening force (N)	3060	6675
Closing/opening Time (s)	0.2/0.2	0.2/0.2
Max. pressure (bar)	7	7
Min. pressure (bar)	3	3
Compressed air consumption (cm <sup>3</sup> )	195	195
Weight(kg)	2.72	2.72
Recom. work piece weight(kg)	14.6	32

## Dimensions

Standard type 12  
Heavy-duty type 6

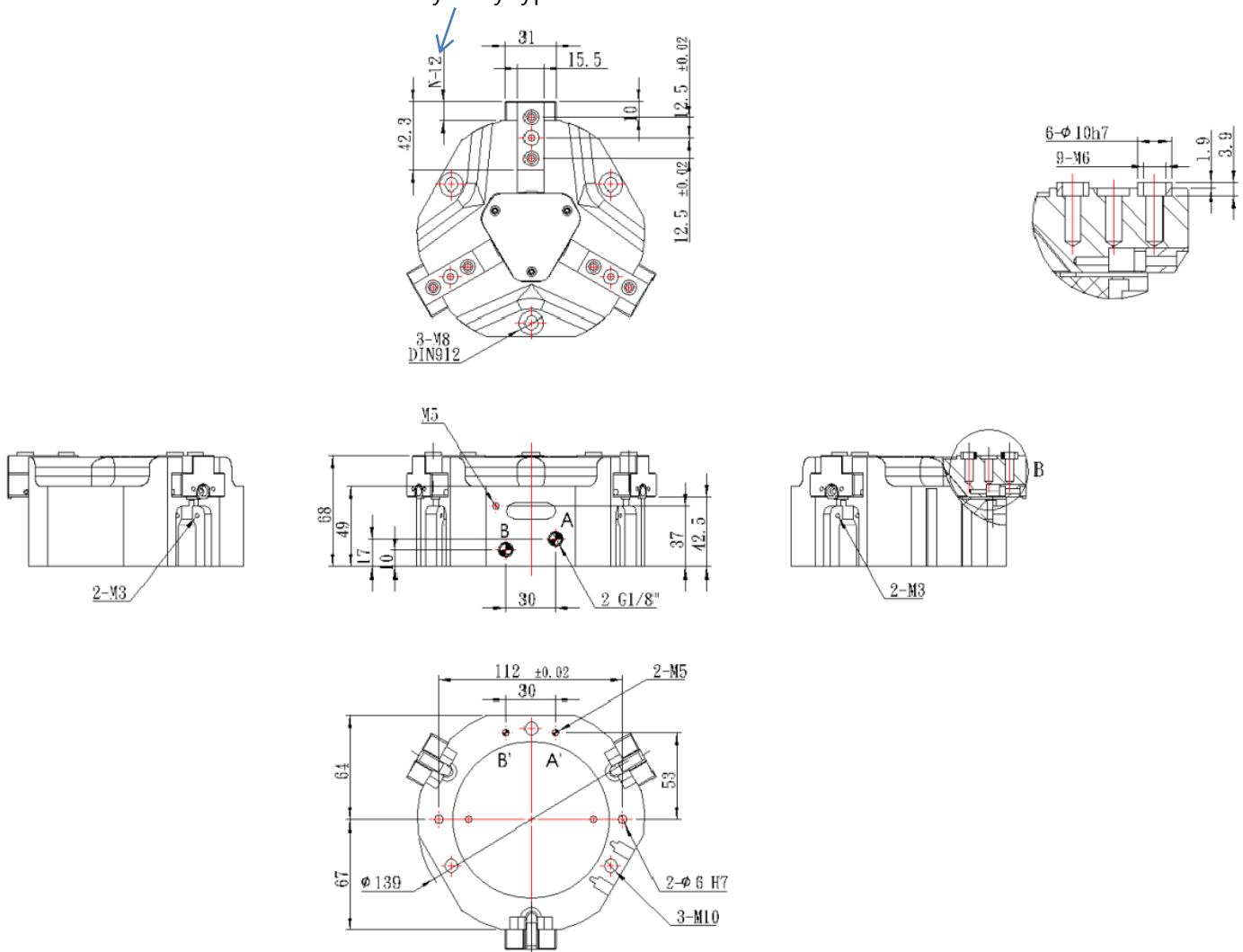

※ This diagram shows the basic dimensions of the main body of the gripper and does not include the dimensions of optional accessories

## GDT-316 / GDT-316-S



Standard Accessories



Optional Accessories

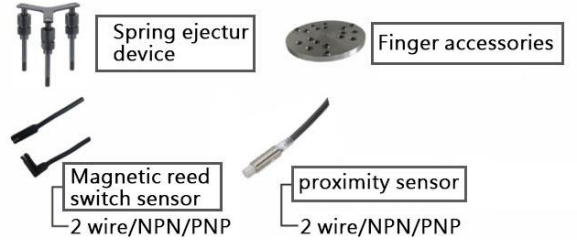

Gripping force

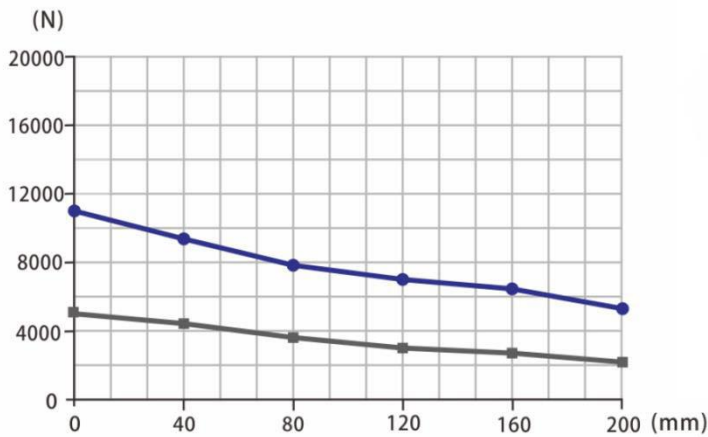

● GDT-316-S Heavy-duty type  
■ GDT-316 Standard type

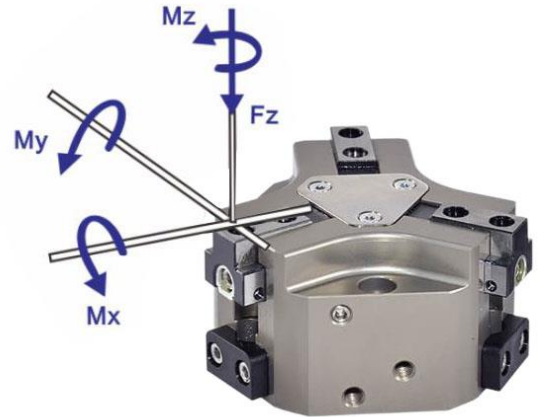

■ Mx max. 130.0 Nm  
■ My max. 145.0 Nm  
■ Mz max. 110.0 Nm  
■ Fz max. 4000.0 N

Spring ejector device Installation diagram

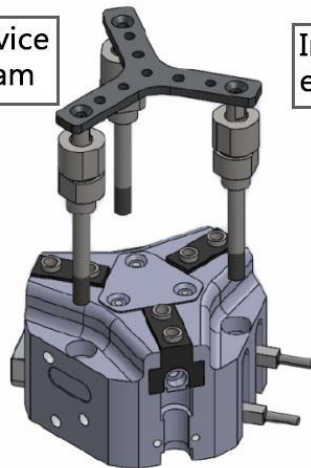

Installation exploded diagram

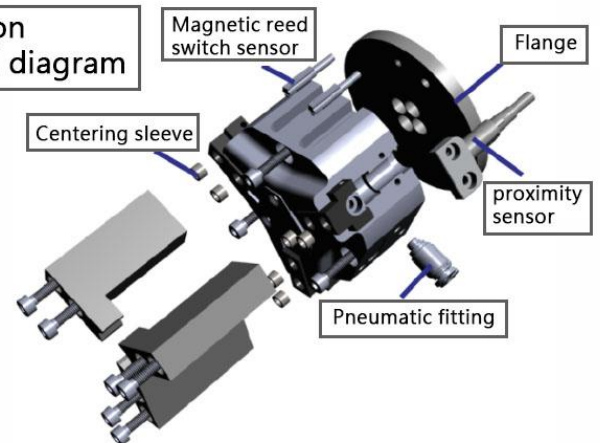



## Specification

Model	GDT-316	GDT-316-S
Stroke per jaw (mm)	16	8
Closing force (N)	5525	11900
Opening force (N)	5610	12240
Closing/opening Time (s)	0.25/0.25	0.25/0.25
Max. pressure (bar)	8	7
Min. pressure (bar)	3	3
Compressed air consumption (cm <sup>3</sup> )	485	485
Weight(kg)	5.2	5.2
Recom. work piece weight(kg)	27	58

## Dimensions

Standard type 16  
Heavy-duty type 8

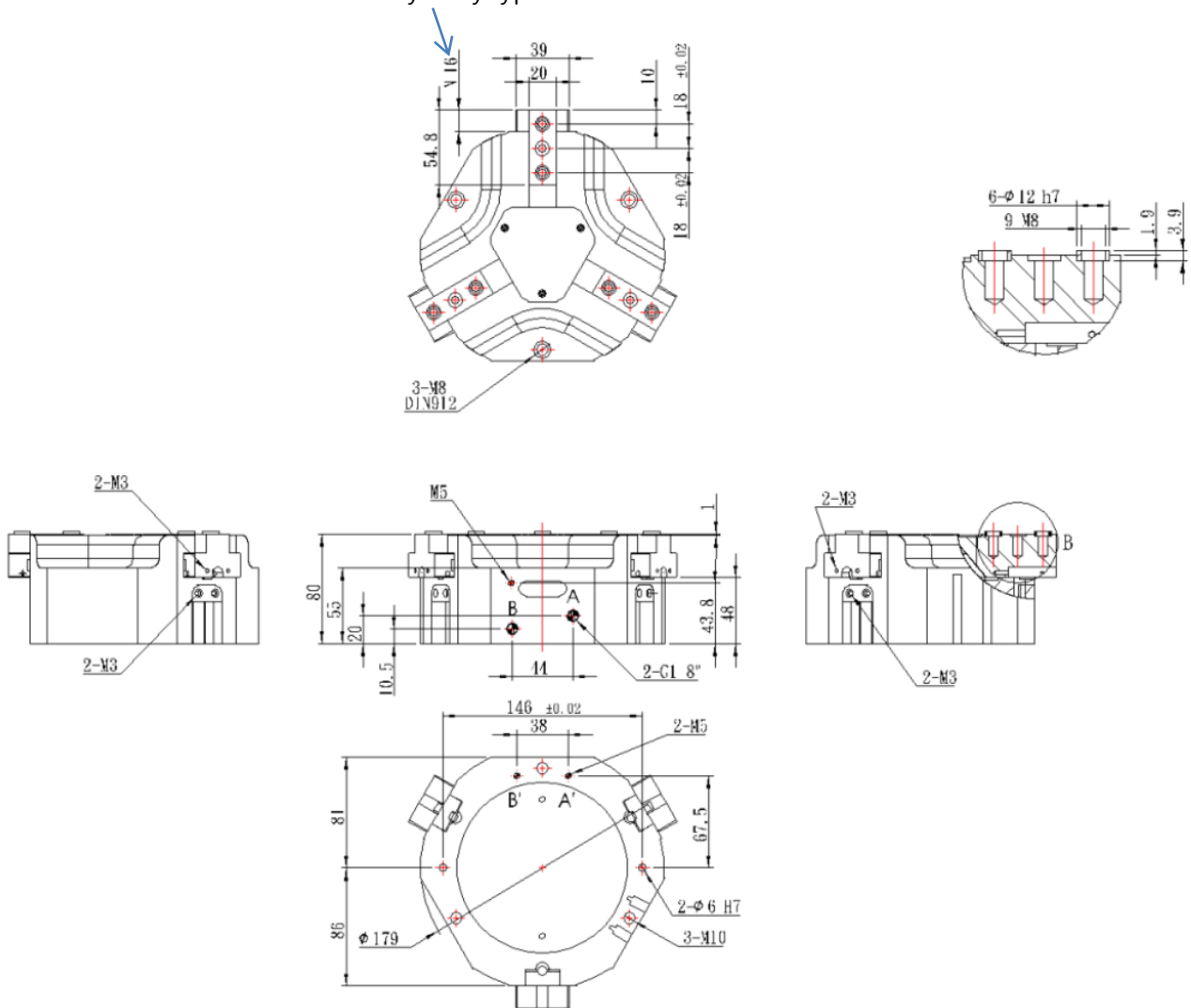

※ This diagram shows the basic dimensions of the main body of the gripper and does not include the dimensions of optional accessories



## GDT-320 / GDT-320-S



Standard Accessories



Optional Accessories

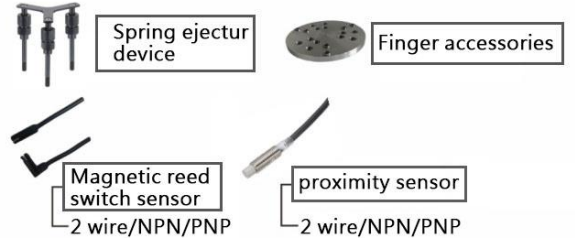

### Gripping force

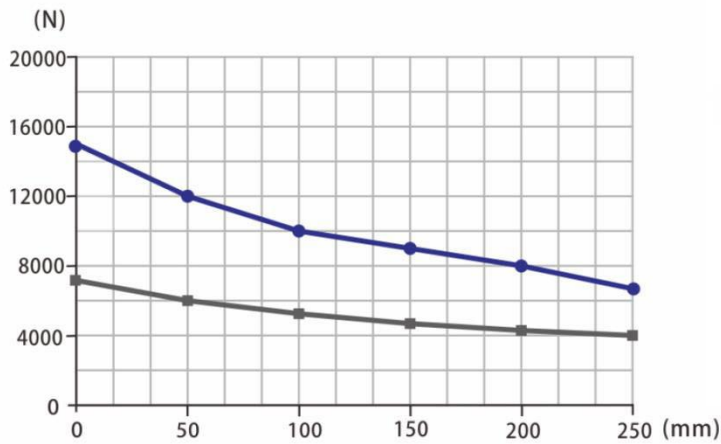

● GDT-320-S Heavy-duty type  
 ■ GDT-320 Standard type

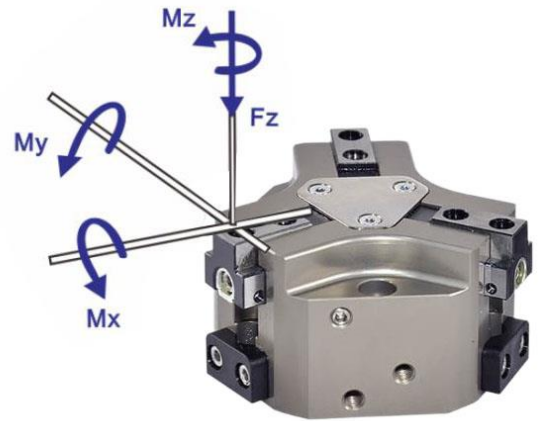

■ Mx max. 145.0 Nm  
 ■ My max. 175.0 Nm  
 ■ Mz max. 135.0 Nm  
 ■ Fz max. 5600.0 N

### Spring ejector device Installation diagram

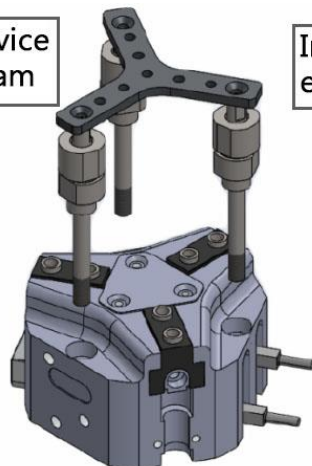

### Installation exploded diagram

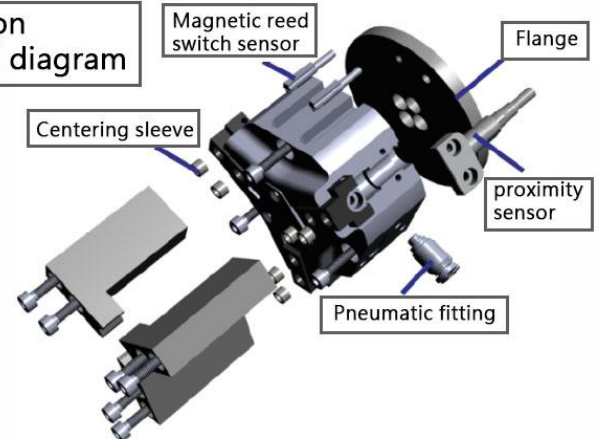



## Specification

Model	GDT-320	GDT-320-S
Stroke per jaw (mm)	20	10
Closing force (N)	6970	15430
Opening force (N)	7185	15895
Closing/opening Time (s)	0.35/0.35	0.35/0.35
Max. pressure (bar)	8	8
Min. pressure (bar)	3	3
Compressed air consumption (cm <sup>3</sup> )	850	850
Weight(kg)	9.7	9.7
Recom. work piece weight(kg)	34.2	76

## Dimensions

Standard type 20  
Heavy-duty type 10

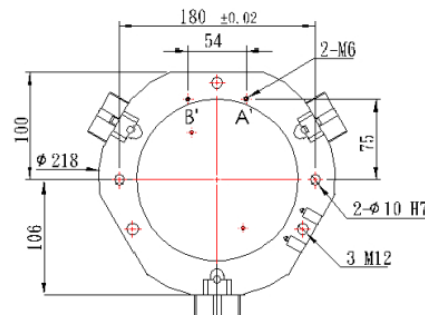
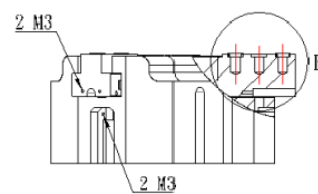
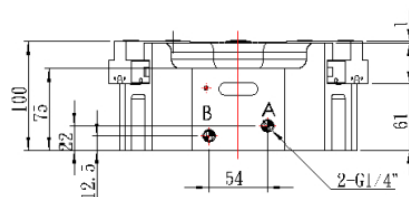
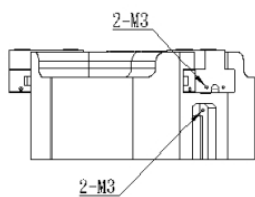
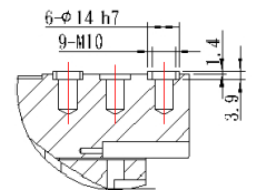
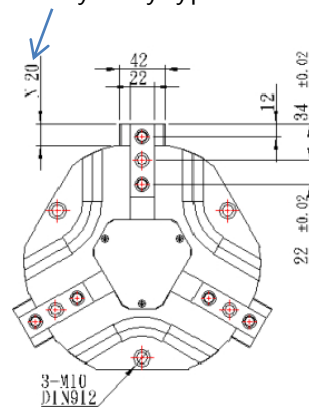

※ This diagram shows the basic dimensions of the main body of the gripper and does not include the dimensions of optional accessories

## GDT-330 / GDT-330-S



Standard Accessories



Optional Accessories

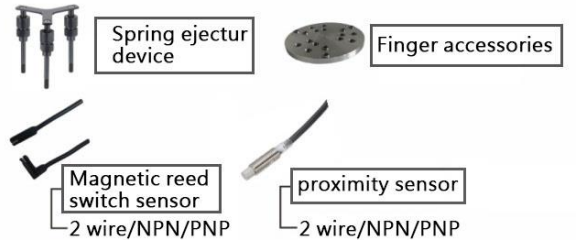

### Gripping force

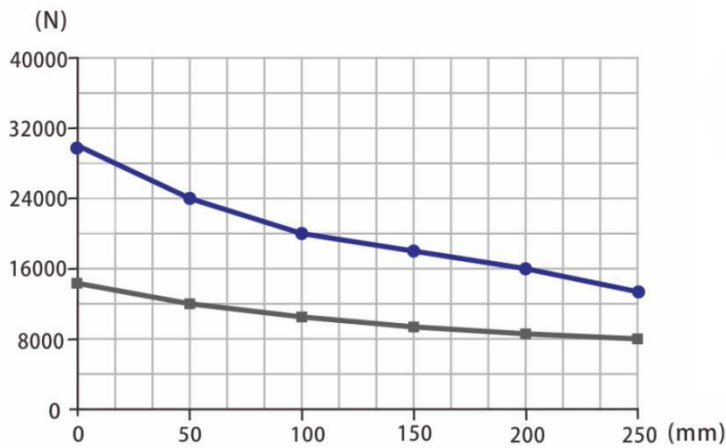

● GDT-330-S Heavy-duty type  
■ GDT-330 Standard type

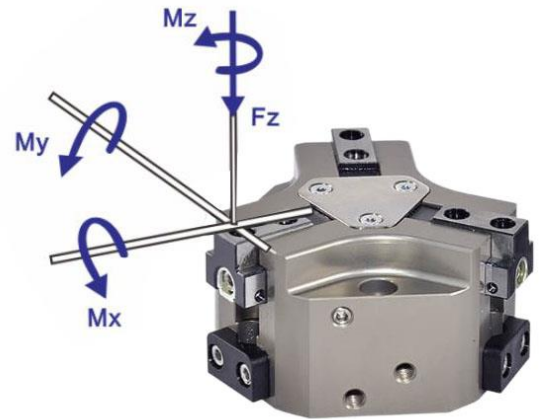

■ Mx max. 220.0 Nm  
■ My max. 240.0 Nm  
■ Mz max. 160.0 Nm  
■ Fz max. 7200.0 N

Spring ejector device  
Installation diagram

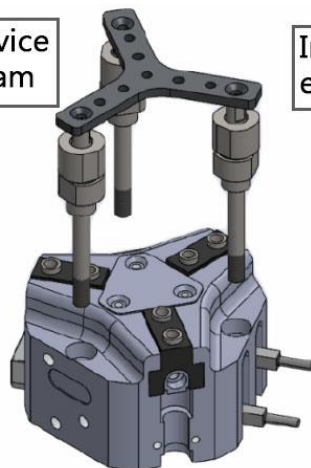

Installation exploded diagram

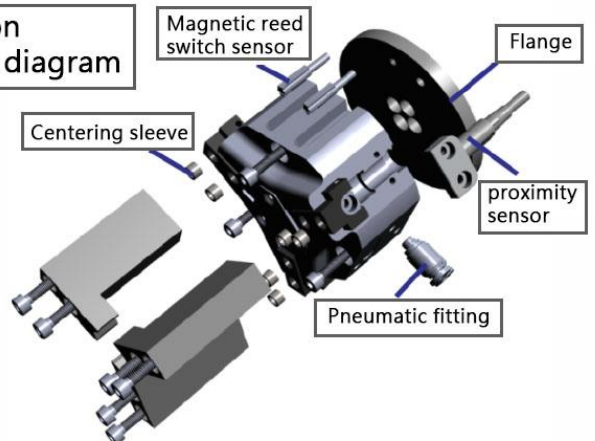





## Specification

Model	GDT-330	GDT-330-S
Stroke per jaw (mm)	30	15
Closing force (N)	13000	29030
Opening force (N)	13220	29500
Closing/opening Time (s)	0.8/0.8	0.8/0.8
Max. pressure (bar)		8
Min. pressure (bar)	3	3
Compressed air consumption (cm <sup>3</sup> )	2300	2300
Weight(kg)	24.5	24.5
Recom. work piece weight(kg)	64	142

## Dimensions

Standard type 30  
Heavy-duty type 15

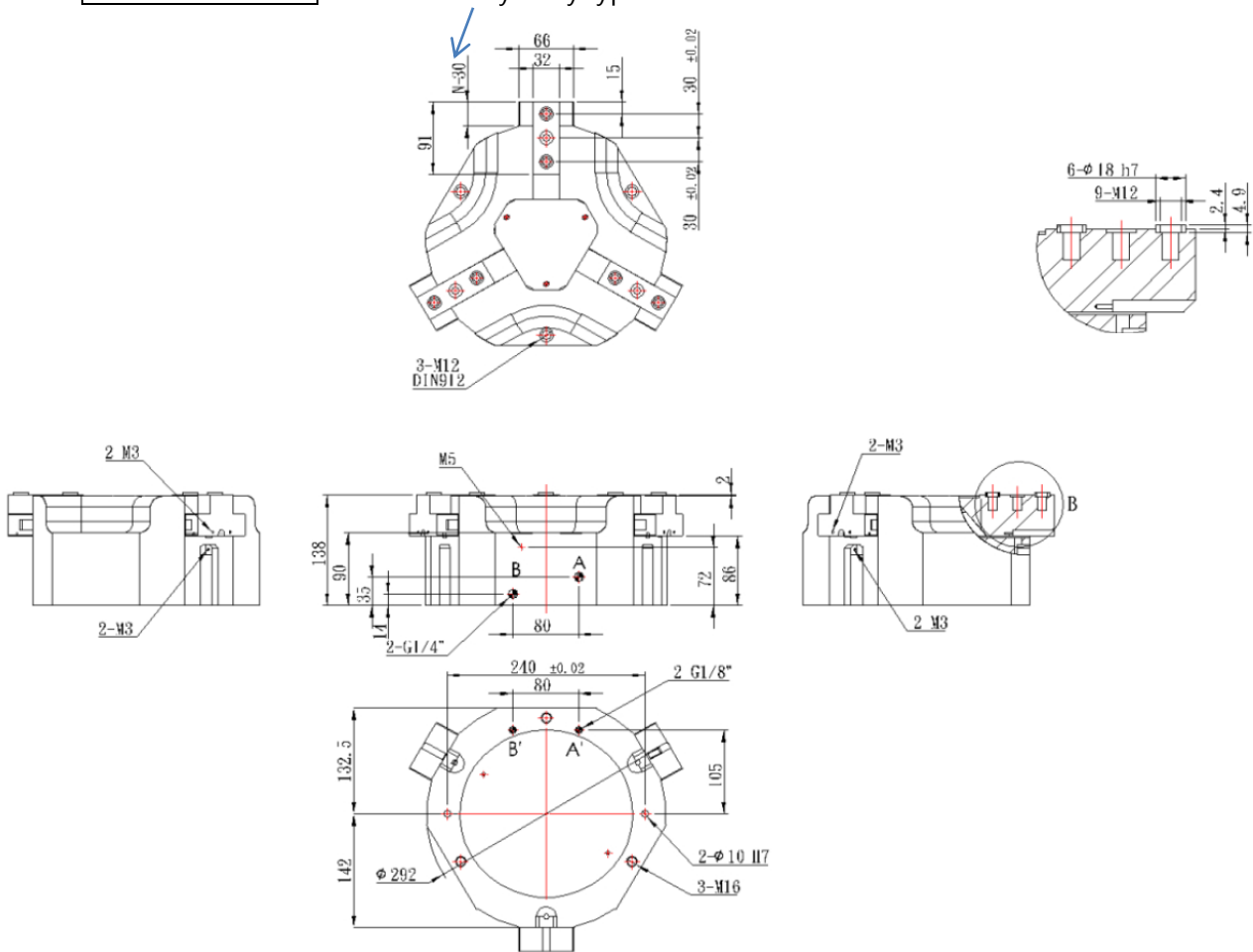

※ This diagram shows the basic dimensions of the main body of the gripper and does not include the dimensions of optional accessories