



GDT 系列

三指定心機械夾爪



產品規格

型號	GDT-304	GDT-306	GDT-308	GDT-310	GDT-312	GDT-316	GDT-320	GDT-330
單爪行程 mm	4	6	8	10	12	16	20	30
關閉力 N	385	640	1020	1700	2975	5525	6970	13000
開啟力 N	425	680	1105	1785	3060	5610	7185	13220
關閉/開啟時間 s	0.025/0.025	0.03/0.03	0.05/0.05	0.1/0.1	0.2/0.2	0.25/0.25	0.35/0.35	0.8/0.8
最大壓力 bar	6	6	7	7	7	7	8	8
最小壓力 bar	3	3	3	3	3	3	3	3
壓縮空氣消耗量 cm ³	8	20.5	45	110	195	485	850	2300
重量 kg	0.23	0.55	0.9	1.62	2.72	5.2	9.7	24.5
建議工作重量 kg	2	3.2	5	8.3	14.6	27	34.2	64

型號	GDT-308-S	GDT-310-S	GDT-312-S	GDT-316-S	GDT-320-S	GDT-330-S
單爪行程 mm	4	5	6	8	10	15
關閉力 N	2210	3740	6460	11900	15430	29030
開啟力 N	2380	3910	6675	12240	15895	29500
關閉/開啟時間 s	0.05/0.05	0.1/0.1	0.2/0.2	0.25/0.25	0.35/0.35	0.8/0.8
最大壓力 bar	7	7	7	7	8	8
最小壓力 bar	3	3	3	3	3	3
壓縮空氣消耗量 cm ³	45	110	195	485	850	2300
重量 kg	0.9	1.62	2.72	5.2	9.7	24.5
建議工作重量 kg	11	18	32	58	76	142

■ GDT-304



標準配件



選用配件

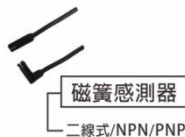

※ 此型號不適用近接感測器



夾持力

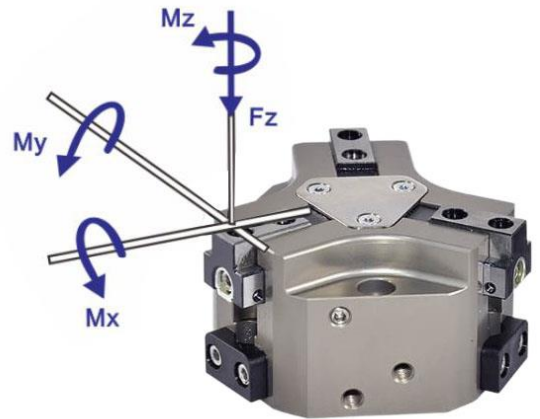
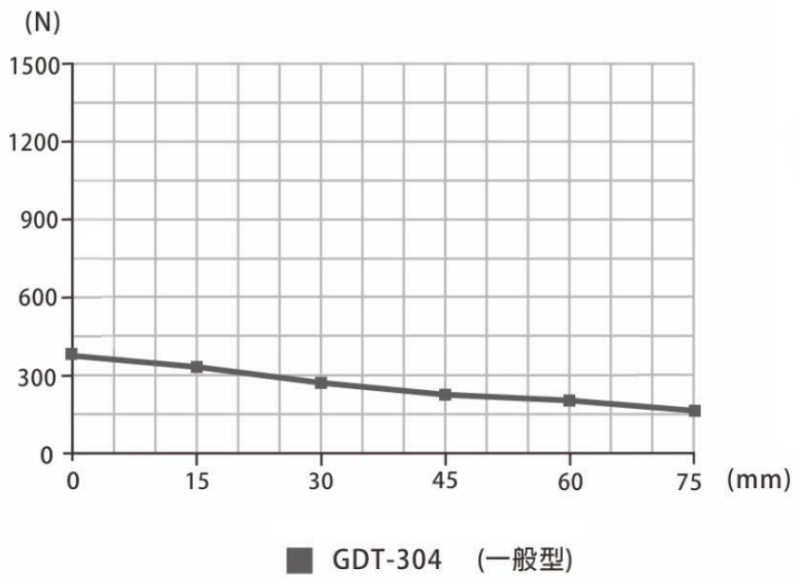

- Mx max. 12.0 Nm
- My max. 12.0 Nm
- Mz max. 6.5 Nm
- Fz max. 560.0 N

頂料裝置安裝圖

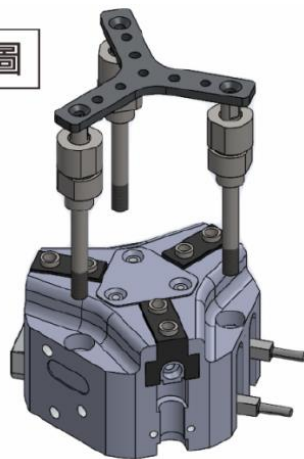

安裝分解圖

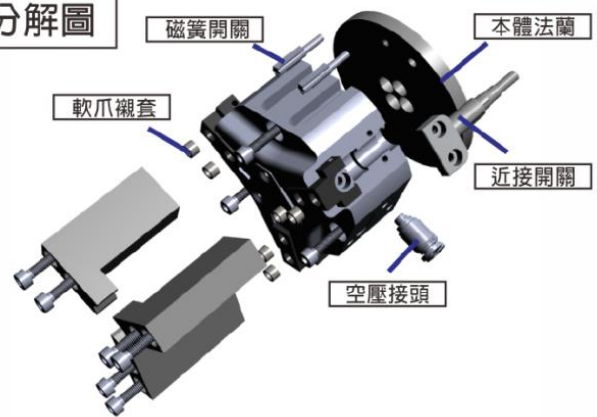

產品規格

型號	GDT-304
單爪行程 mm	4
關閉力 N	385
開啟力 N	425
關閉/開啟時間 s	0.025/0.025
最大壓力 bar	6
最小壓力 bar	3
壓縮空氣消耗量 cm ³	8
重量 kg	0.23
建議工作重量 kg	2



外觀尺寸圖

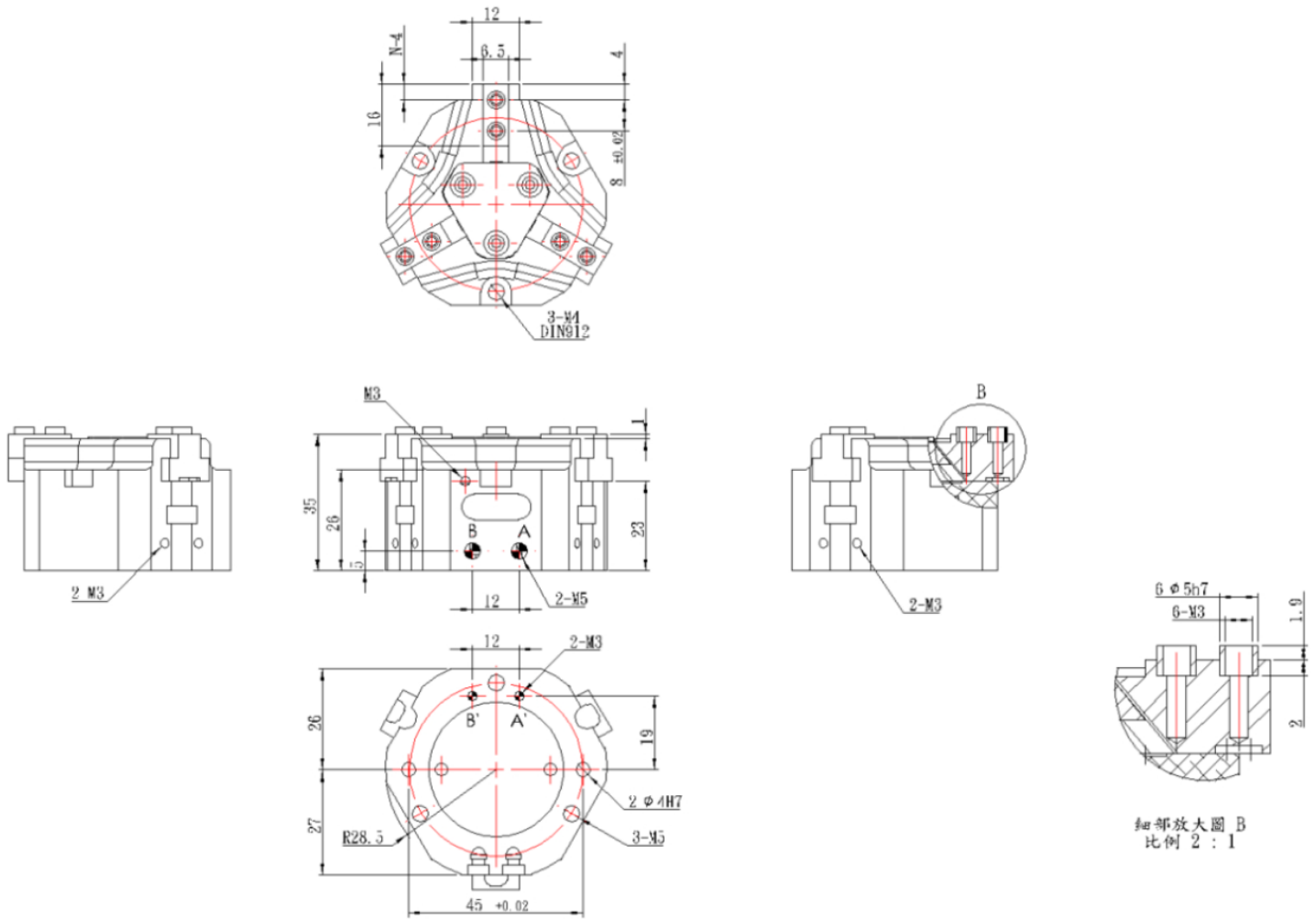

※ 此圖為夾爪本體的基本尺寸，不含選配物件尺寸



GDT-306



標準配件



選用配件

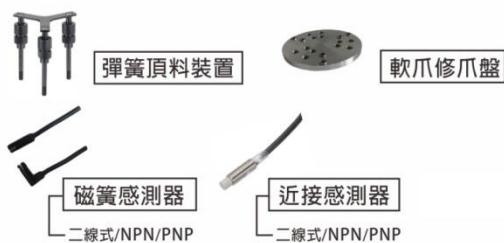

夾持力

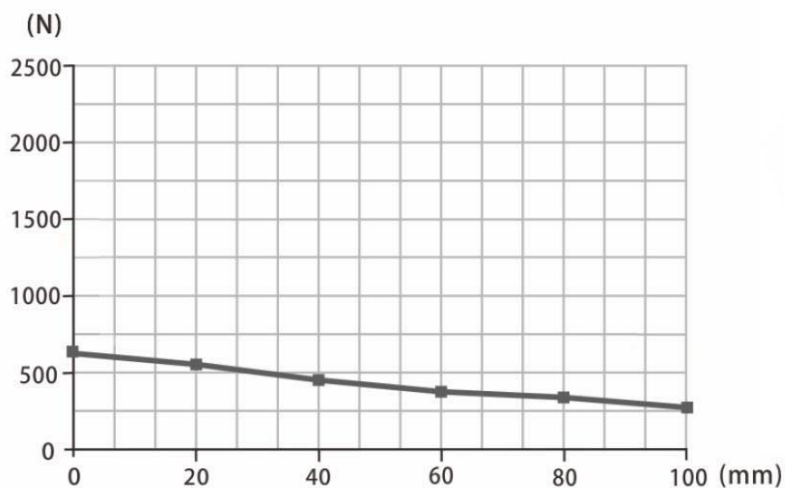

■ GDT-306 (一般型)

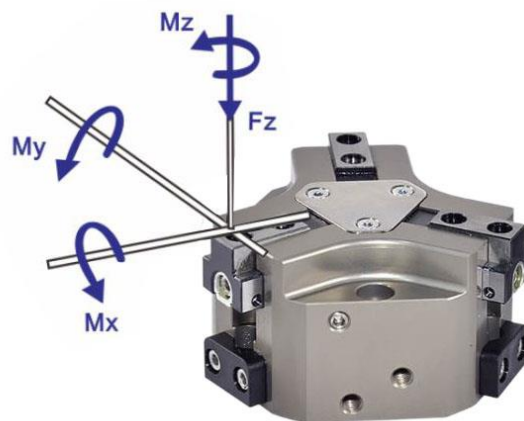

- Mx max. 40.0 Nm
- My max. 36.0 Nm
- Mz max. 28.0 Nm
- Fz max. 960.0 N

頂料裝置安裝圖

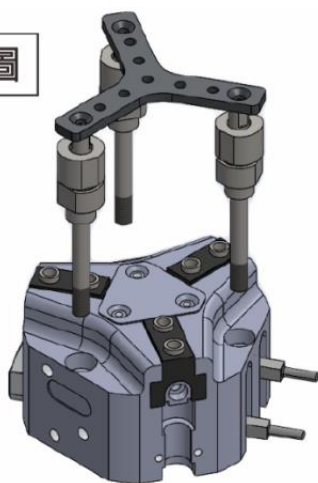

安裝分解圖

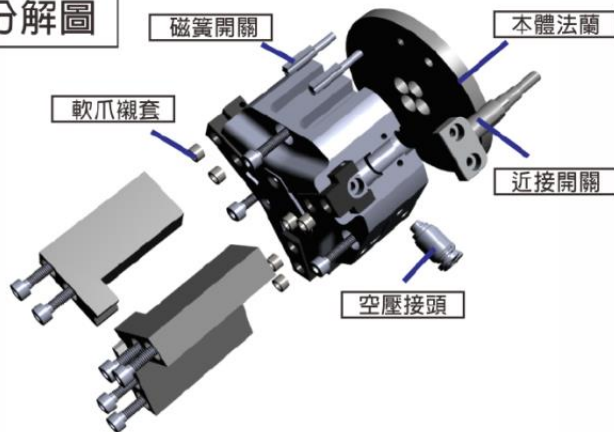



產品規格

型號	GDT-306
單爪行程 mm	6
關閉力 N	640
開啟力 N	680
關閉/開啟時間 s	0.03/0.03
最大壓力 bar	6
最小壓力 bar	3
壓縮空氣消耗量 cm ³	20.5
重量 kg	0.55
建議工作重量 kg	3.2

外觀尺寸圖

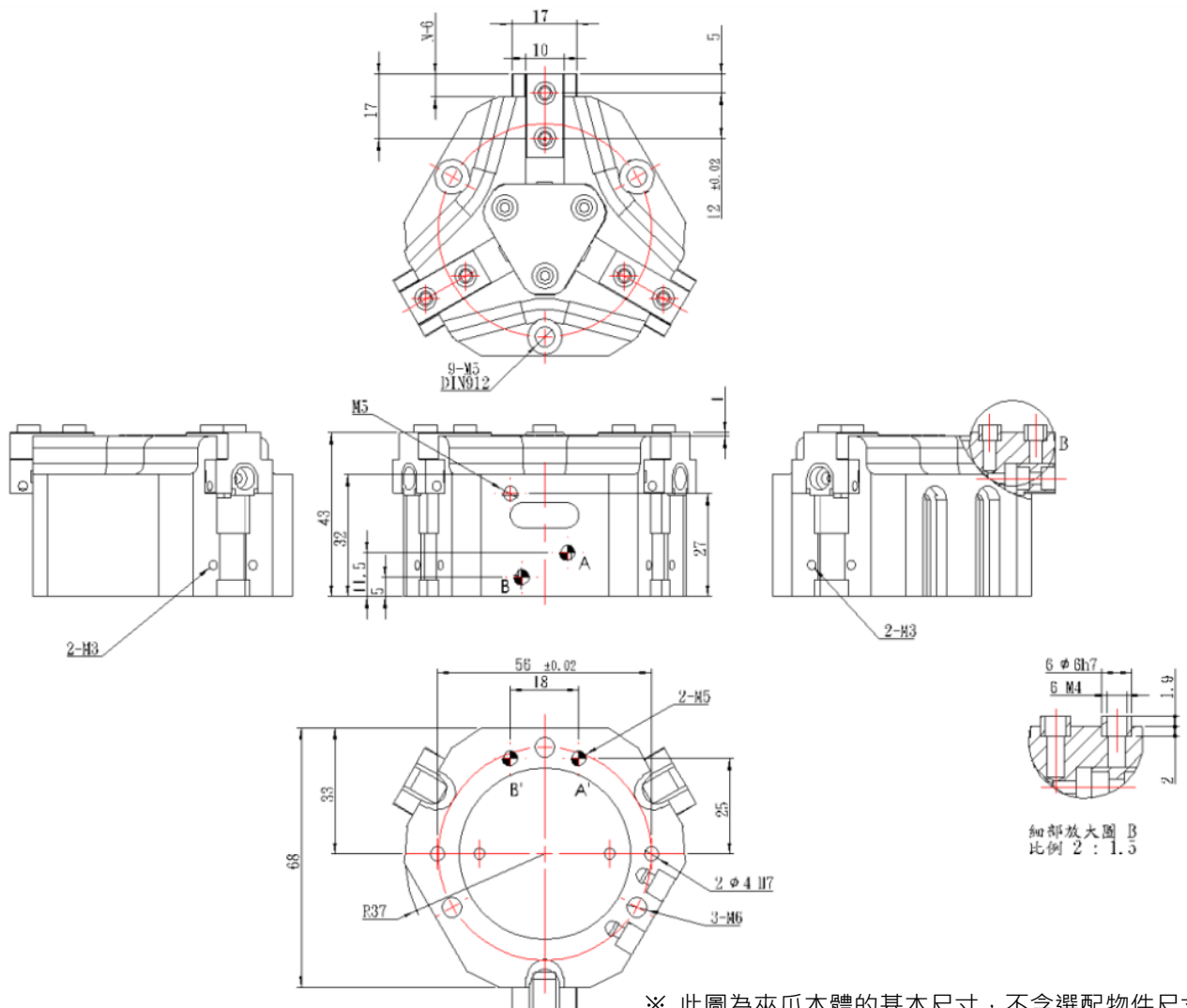



GDT-308 / GDT-308-S



標準配件

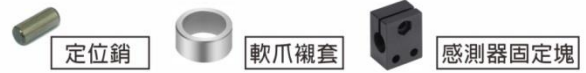

選用配件

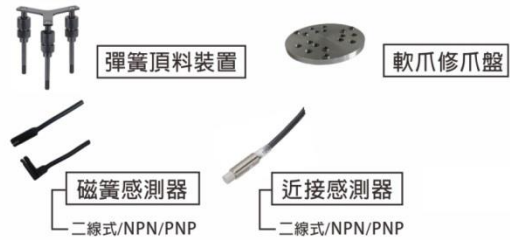

夾持力

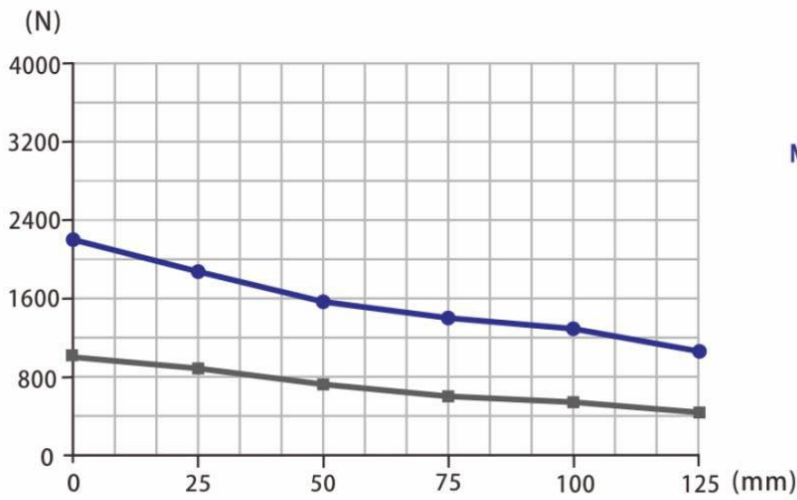

● GDT-308-S (強力型)
■ GDT-308 (一般型)

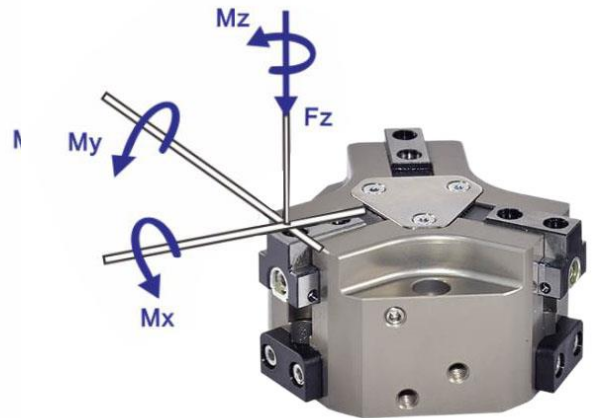

■ Mx max. 65.0 Nm
■ My max. 48.0 Nm
■ Mz max. 40.0 Nm
■ Fz max. 1440.0 N

頂料裝置安裝圖

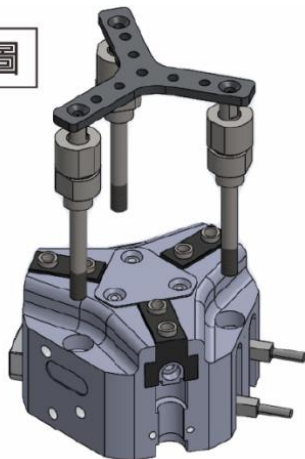

安裝分解圖

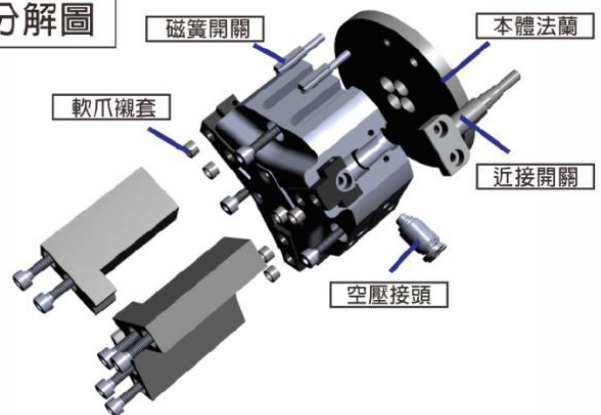



產品規格

型號	GDT-308	GDT-308-S
單爪行程 mm	8	4
關閉力 N	1020	2210
開啟力 N	1105	2380
關閉/開啟時間 s	0.05/0.05	0.05/0.05
最大壓力 bar	7	7
最小壓力 bar	3	3
壓縮空氣消耗量 cm ³	45	45
重量 kg	0.9	0.9
建議工作重量 kg	5	11

外觀尺寸圖

8 為一般型行程
強力型行程 4

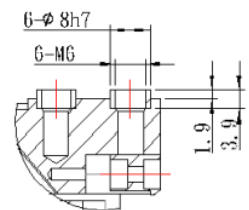
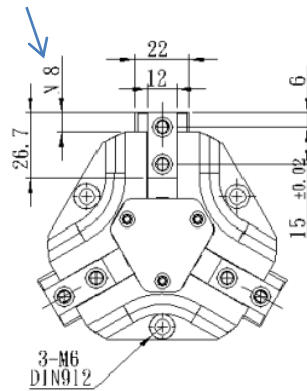

細部放大圖 B
比例 1 : 1

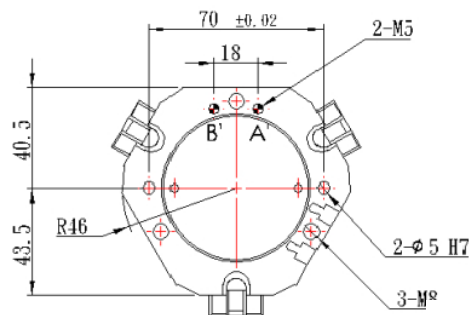
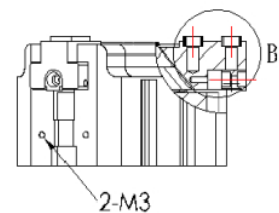
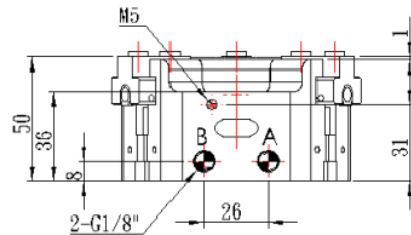
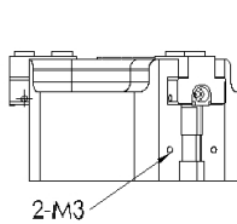

※ 此圖為夾爪本體的基本尺寸，不含選配物件尺寸



GDT-310 / GDT-310-S



標準配件



選用配件

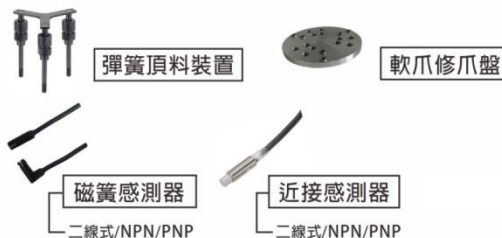

夾持力

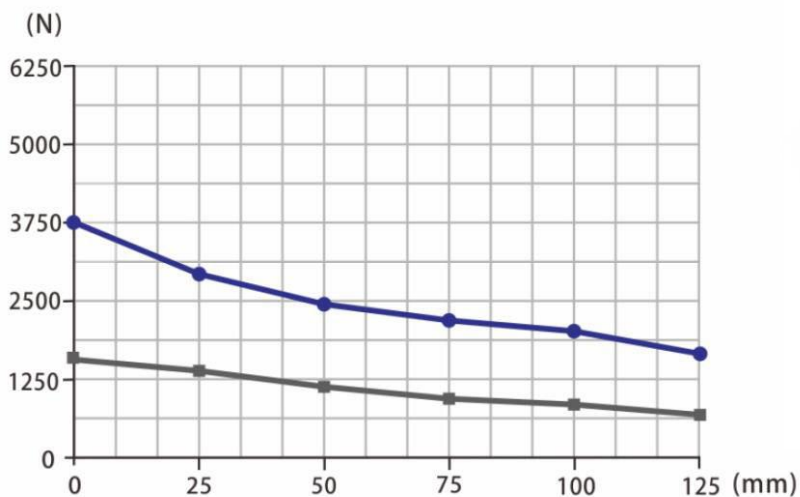

● GDT-310-S (強力型)
■ GDT-310 (一般型)

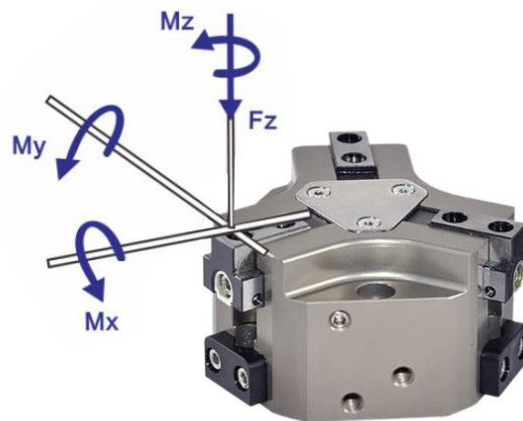

- Mx max. 80.0 Nm
- My max. 72.0 Nm
- Mz max. 60.0 Nm
- Fz max. 2000.0 N

頂料裝置安裝圖

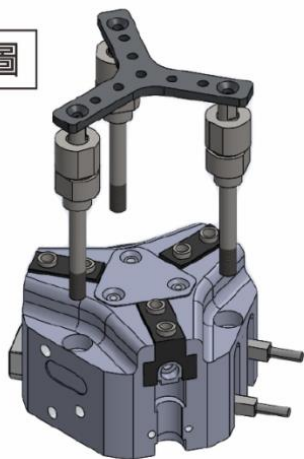

安裝分解圖

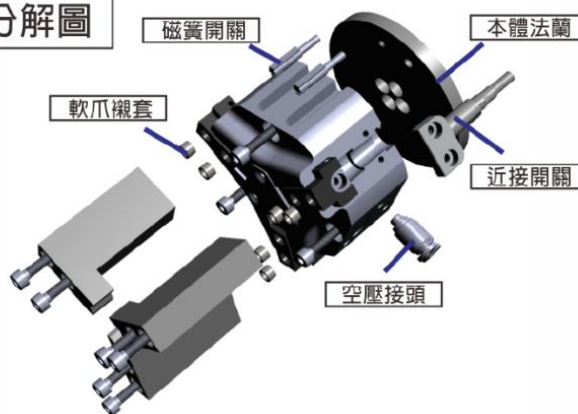



產品規格

型號	GDT-310	GDT-310-S
單爪行程 mm	10	5
關閉力 N	1700	3740
開啟力 N	1785	3910
關閉/開啟時間 s	0.1/0.1	0.1/0.1
最大壓力 bar	7	7
最小壓力 bar	3	3
壓縮空氣消耗量 cm ³	110	110
重量 kg	1.62	1.62
建議工作重量 kg	8.3	18

外觀尺寸圖

10 為一般型行程
 強力型行程 5

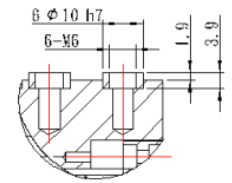
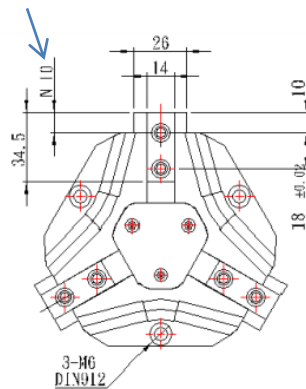

細部放大圖 B
 比例 1 : 1

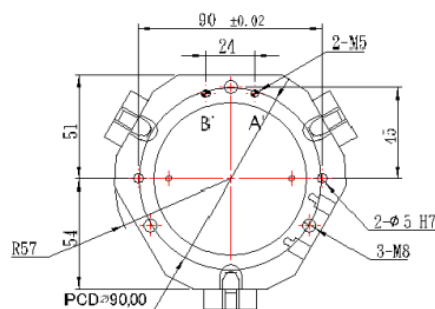
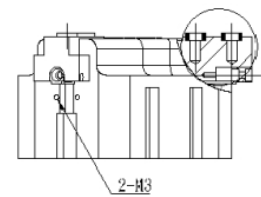
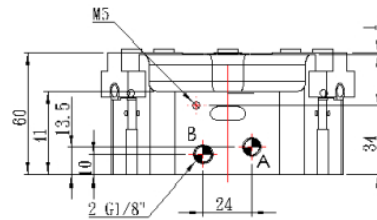
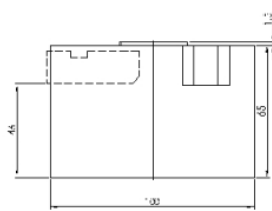

※ 此圖為夾爪本體的基本尺寸，不含選配物件尺寸



GDT-312 / GDT-312-S



標準配件

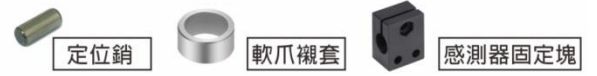

選用配件

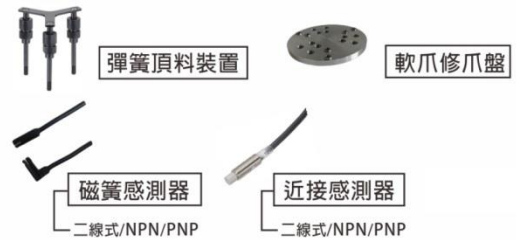

夾持力

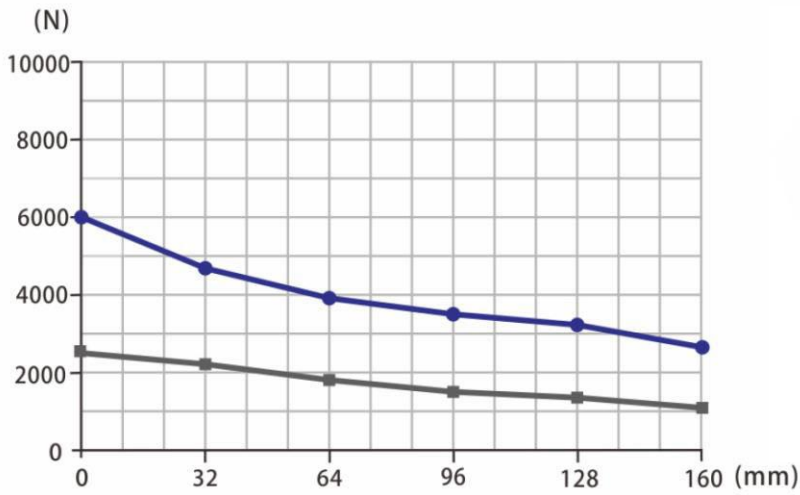

● GDT-312-S (強力型)
■ GDT-312 (一般型)

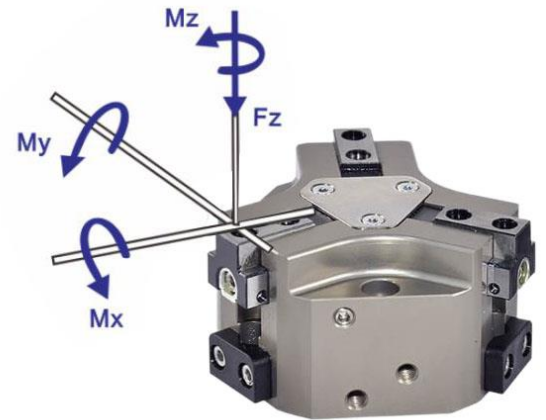

■ Mx max. 95.0 Nm
■ My max. 96.0 Nm
■ Mz max. 80.0 Nm
■ Fz max. 2560.0 N

頂料裝置安裝圖

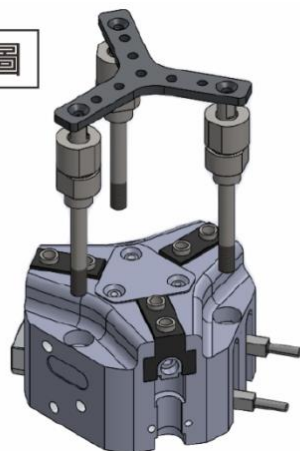

安裝分解圖

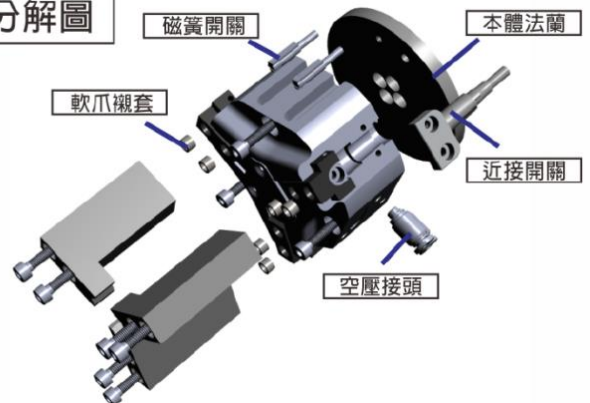



產品規格

型號	GDT-312	GDT-312-S
單爪行程 mm	12	6
關閉力 N	2975	6460
開啟力 N	3060	6675
關閉/開啟時間 s	0.2/0.2	0.2/0.2
最大壓力 bar	7	7
最小壓力 bar	3	3
壓縮空氣消耗量 cm ³	195	195
重量 kg	2.72	2.72
建議工作重量 kg	14.6	32

外觀尺寸圖

12 為一般型行程
 強力型行程 6

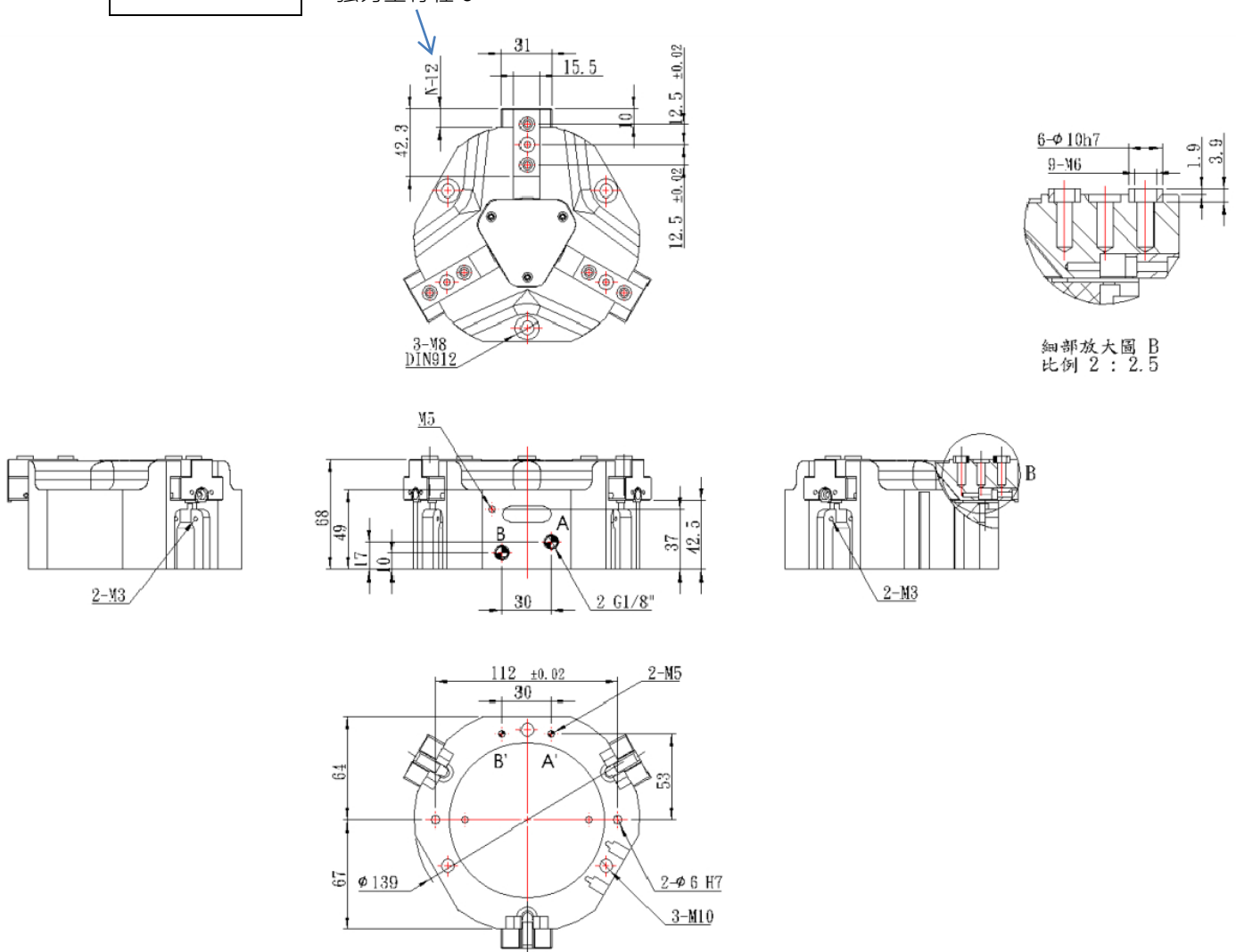

※ 此圖為夾爪本體的基本尺寸，不含選配物件尺寸



GDT-316 / GDT-316-S



標準配件



選用配件

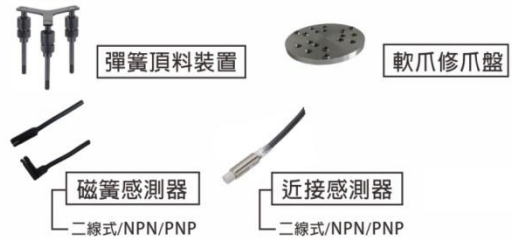

夾持力

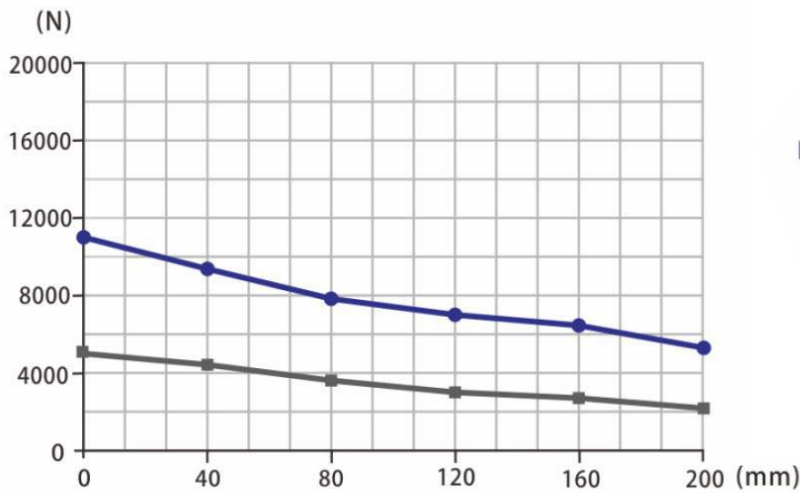

● GDT-316-S (強力型)
■ GDT-316 (一般型)

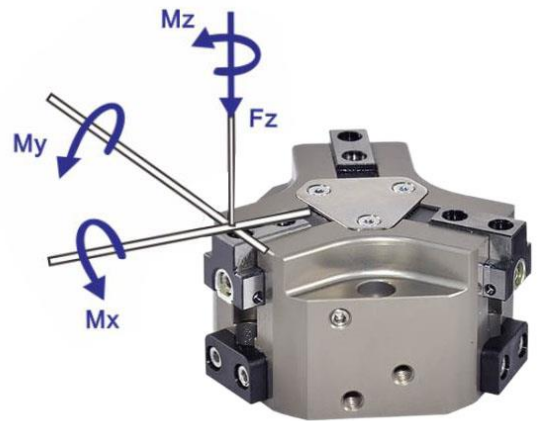

■ Mx max. 130.0 Nm
■ My max. 145.0 Nm
■ Mz max. 110.0 Nm
■ Fz max. 4000.0 N

頂料裝置安裝圖

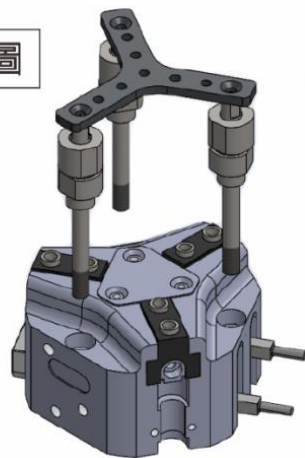

安裝分解圖

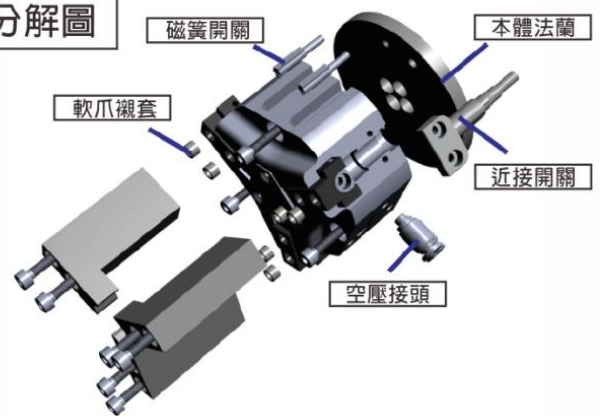



產品規格

型號	GDT-316	GDT-316-S
單爪行程 mm	16	8
關閉力 N	5525	11900
開啟力 N	5610	12240
關閉/開啟時間 s	0.25/0.25	0.25/0.25
最大壓力 bar	7	7
最小壓力 bar	3	3
壓縮空氣消耗量 cm ³	485	485
重量 kg	5.2	5.2
建議工作重量 kg	27	58

外觀尺寸圖

16 為一般型行程
強力型行程 8

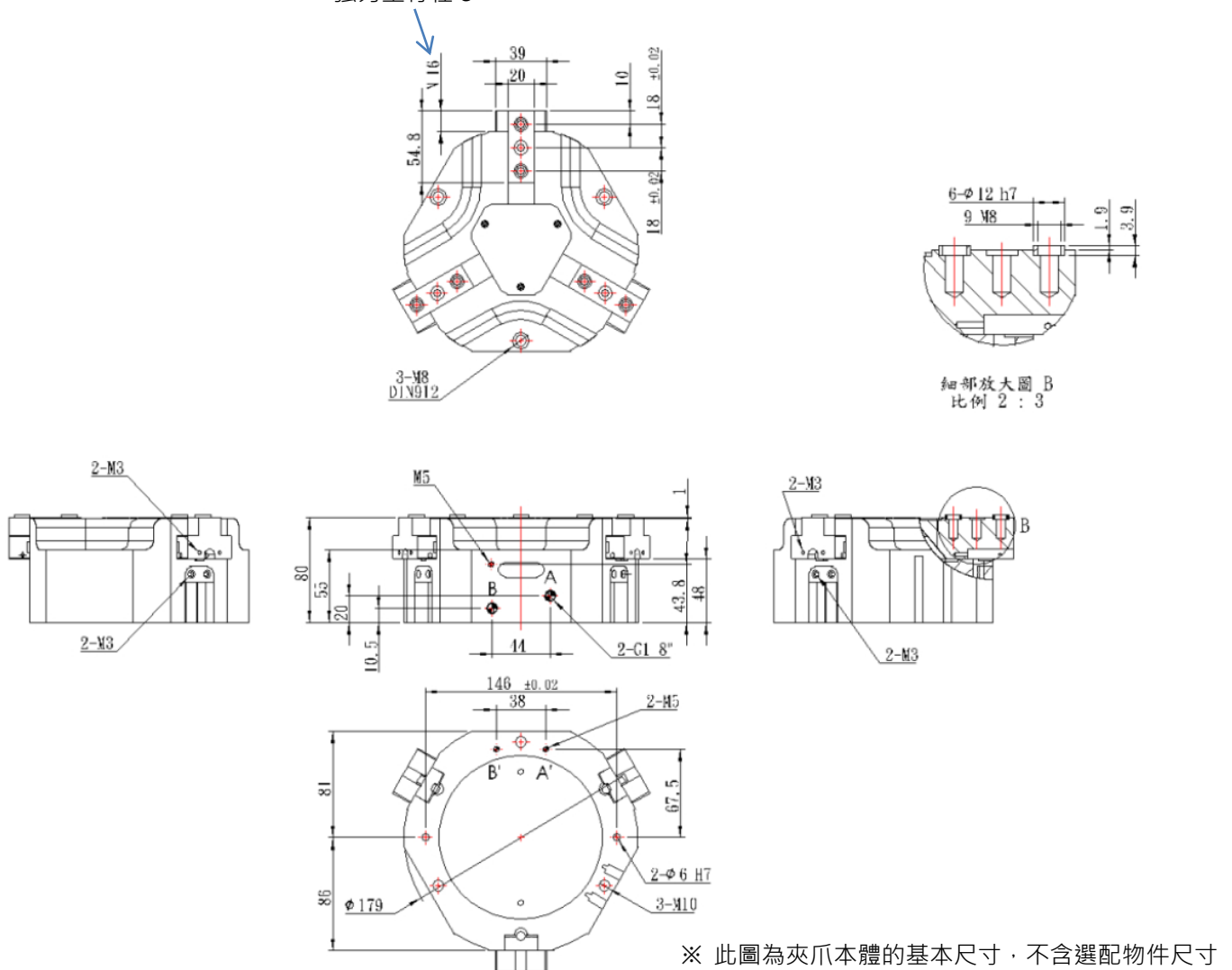



GDT-320 / GDT-320-S



標準配件



選用配件

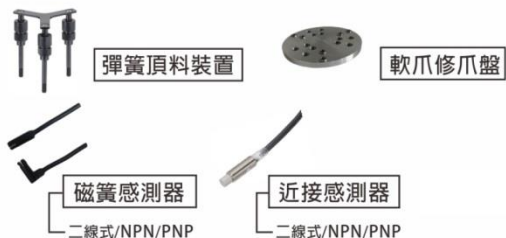

夾持力

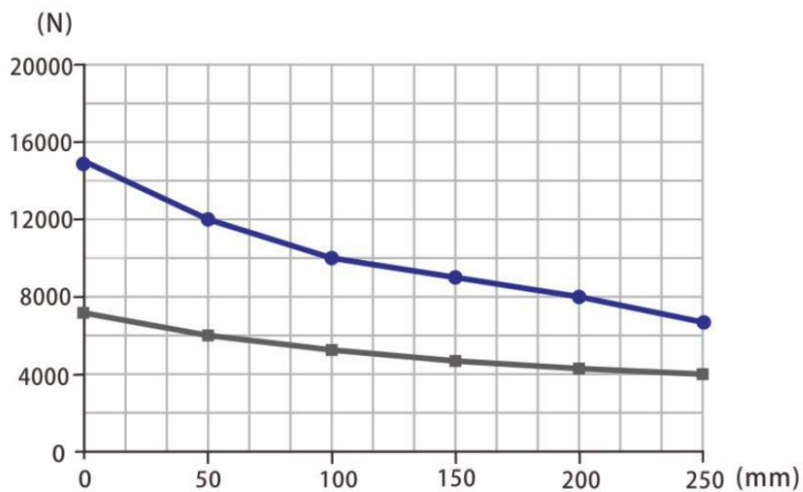

● GDT-320-S (強力型)
■ GDT-320 (一般型)

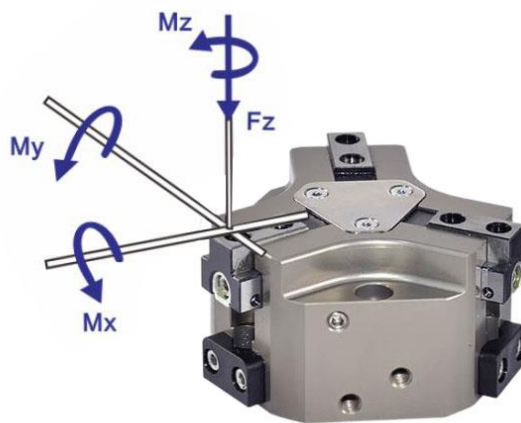

- Mx max. 145.0 Nm
- My max. 175.0 Nm
- Mz max. 135.0 Nm
- Fz max. 5600.0 N

頂料裝置安裝圖

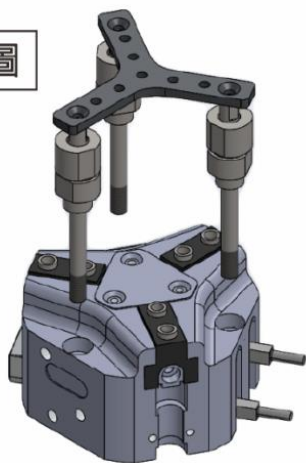

安裝分解圖

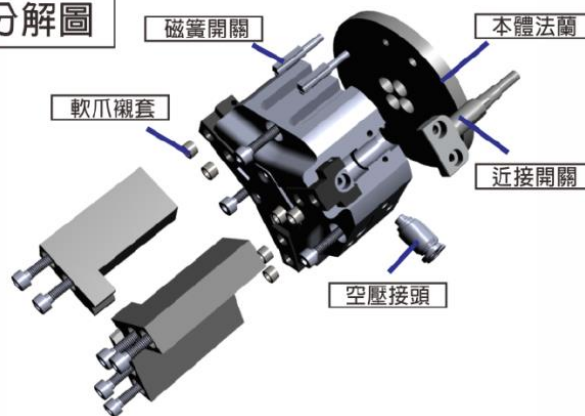



產品規格

型號	GDT-320	GDT-320-S
單爪行程 mm	20	10
關閉力 N	6970	15430
開啟力 N	7185	15895
關閉/開啟時間 s	0.35/0.35	0.35/0.35
最大壓力 bar	8	8
最小壓力 bar	3	3
壓縮空氣消耗量 cm ³	850	850
重量 kg	9.7	9.7
建議工作重量 kg	34.2	76

外觀尺寸圖

20 為一般型行程
強力型行程 10

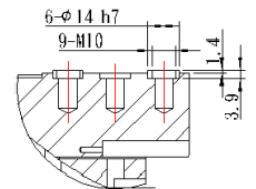
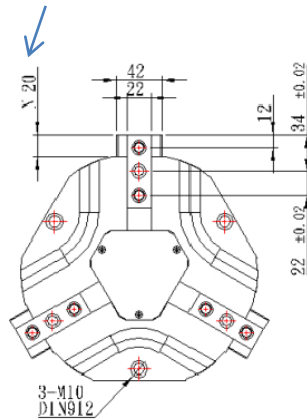

細部放大圖 B
比例 1 : 2

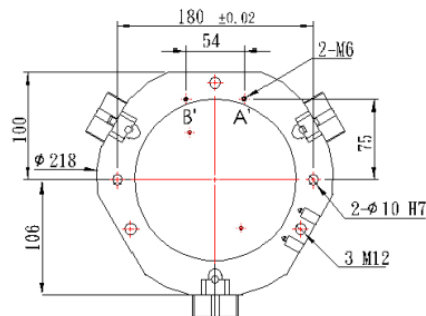
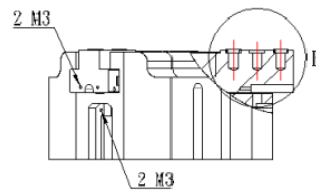
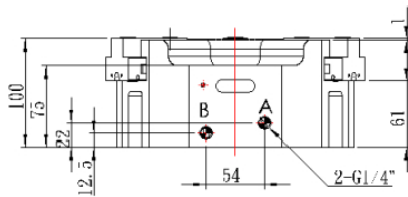
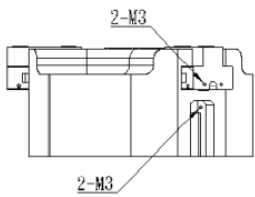

※ 此圖為夾爪本體的基本尺寸，不含選配物件尺寸



GDT-330 / GDT-330-S



標準配件



選用配件

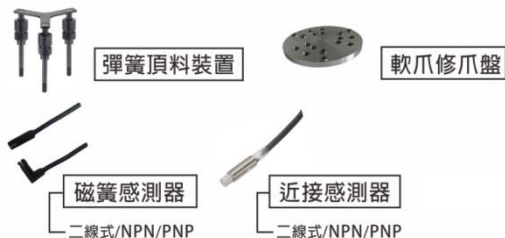

夾持力

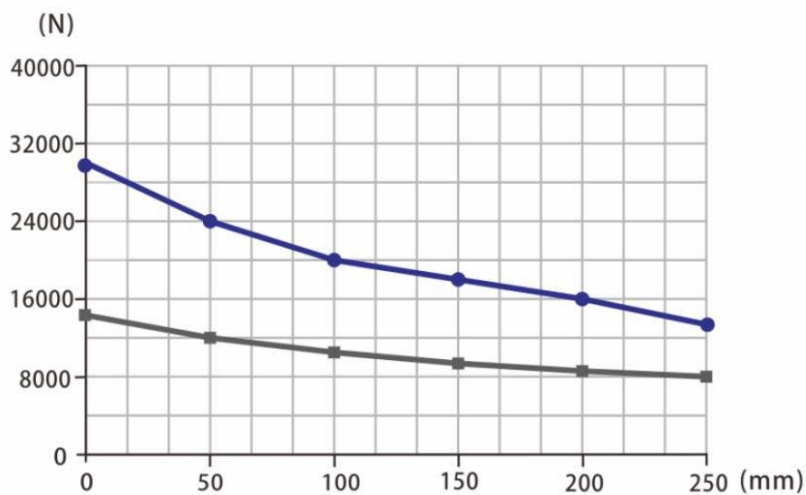

● GDT-330-S (強力型)
■ GDT-330 (一般型)

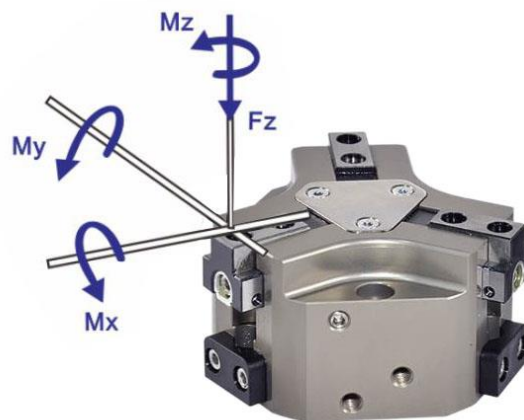

■ Mx max. 220.0 Nm
■ My max. 240.0 Nm
■ Mz max. 160.0 Nm
■ Fz max. 7200.0 N

頂料裝置安裝圖

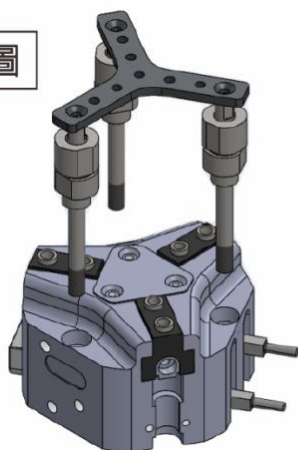

安裝分解圖

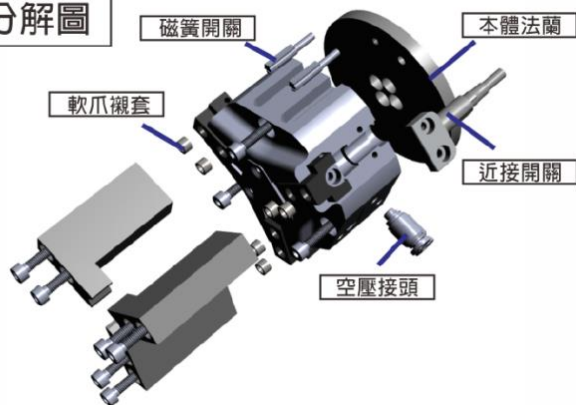



產品規格

型號	GDT-330	GDT-330-S
單爪行程 mm	30	15
關閉力 N	13000	29030
開啟力 N	13220	29500
關閉/開啟時間 s	0.8/0.8	0.8/0.8
最大壓力 bar	8	8
最小壓力 bar	3	3
壓縮空氣消耗量 cm ³	2300	2300
重量 kg	24.5	24.5
建議工作重量 kg	64	142

外觀尺寸圖

30 為一般型行程
強力型行程 15

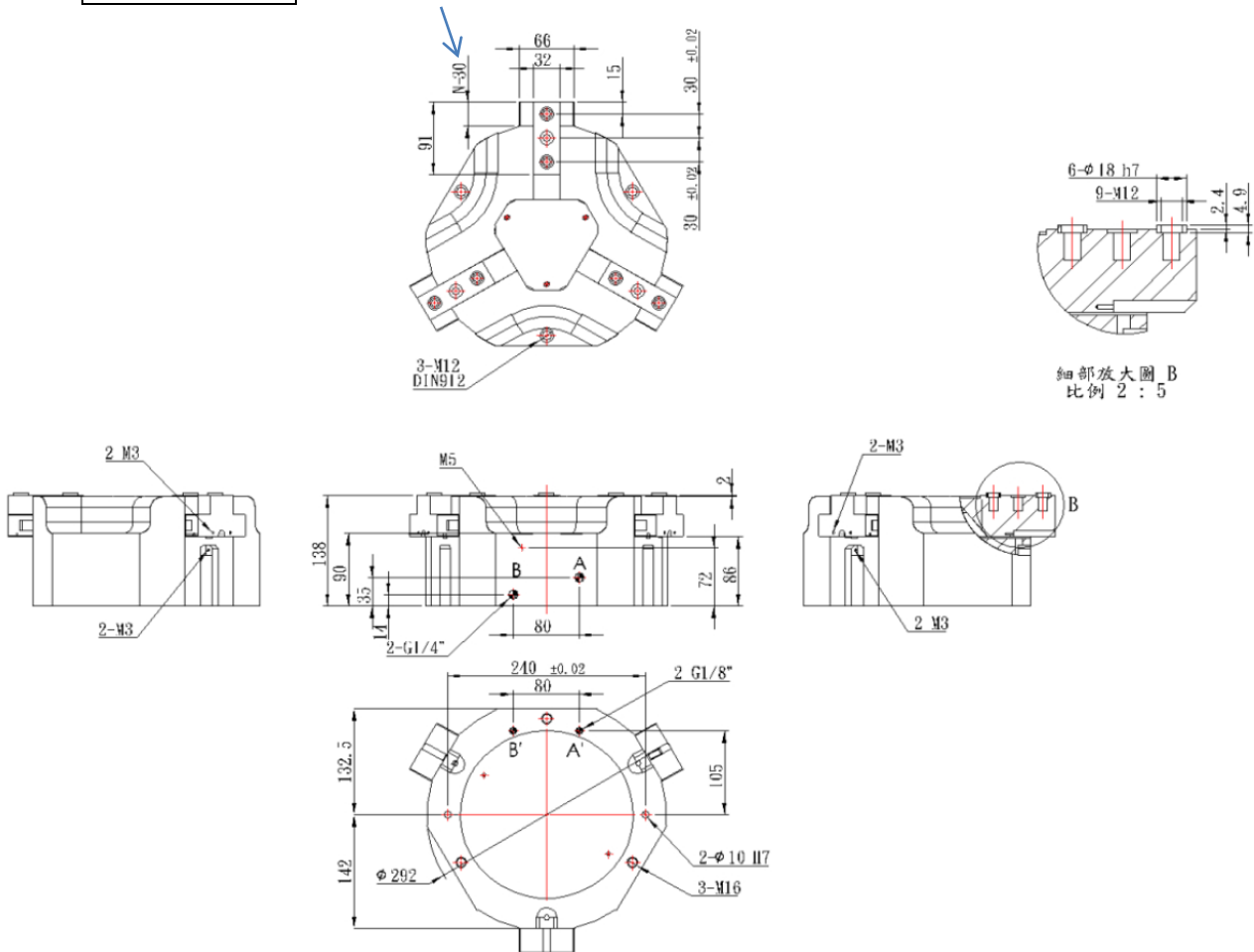

※ 此圖為夾爪本體的基本尺寸，不含選配物件尺寸