

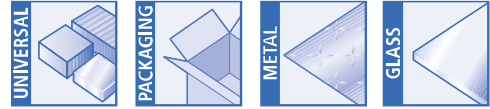

SPB1

波紋吸盤

適於紙箱搬運的耐磨扁平吸盤



介紹及應用

- 應用：圓形 1.5 折波紋吸盤，本體加固設計，具有良好的緩衝性能，吸盤變形量大，適用於搬運硬質包裝，以及金屬薄板和玻璃。
- 靈活性、貼合性俱佳的密封唇
- 吸盤密封唇與波紋之間有防位移結構
- 有效吸取面積大
- 高耐磨材質 Elastodur ED-65
- 應用在搬運紙箱與硬紙板包裝時密封效果優異
- 在高加速度和強靜態阻力下進行準確、剛性搬運
- 體積小，吸力大
- 耐磨性極好，約為 NBR 材質壽命的 3 倍

型號訂購指南

SPB1 **30** **ED-65** **G1/8-AG** **F**
 ① ② ③ ④

吸盤直徑 ⁽¹⁾		② 橡膠件		③ 連接頭螺紋		④ 濾網	
代碼	直徑	代碼	材質	代碼	螺紋	代碼	描述
10	Ø 9.8 mm	ED-65	Elastodur	無	不帶吸盤接頭	無	無過濾器
15	Ø 15.4 mm			M5-AG	M5外螺紋	F	帶過濾器
20	Ø 21.4 mm			M5-IG	M5內螺紋		
25	Ø 26.4 mm			G1/8-AG	G1/8外直螺紋		
30	Ø 31.4 mm			G1/8-IG	G1/8內直		
40	Ø 41.4 mm			G1/4-AG	G1/4外直螺紋		
50	Ø 51.4 mm			G1/4-IG	G1/4內直螺紋		
60	Ø 61.4 mm						
80	Ø 81.4 mm						

(1)吸盤直徑和螺紋型號的可用組合請參見“訂購參數”。



SPB1 技術參數

型號	吸力 [N] ⁽²⁾	拉脫力 [N] ⁽²⁾	側向力 [N]	體積 [cm ³]	工件最小曲率半徑 (凸形)[mm]	推薦真空管內徑 (軟管長度:最長2m)[mm]	適配 吸盤接頭
SPB1-10-...	1.5	4.0	2.0	0.5	5	4	SC 030
SPB1-15-...	4.3	9.0	5.0	1.5	8	4	SC 040
SPB1-20-...	9.9	16.2	9.8	3.1	20	4	SC 040
SPB1-25-...	14.9	23.4	13.0	5.3	20	4	SC 040
SPB1-30-...	20.7	30.6	15.5	8.0	35	6	SC 040
SPB1-40-...	35.9	46.8	24.8	18.3	70	6	SC 050
SPB1-50-...	54.7	72.7	31.2	30.2	100	6	SC 050
SPB1-60-...	78.0	100.9	49.4	49.2	200	6	SC 050
SPB1-80-...	166.0	200.0	59.0	98.4	100	6	SC 065

(2)上述規定吸力為在真空度為-0.6 bar 時的理論值，對於表面光滑、乾燥的工件而言，未包括安全係數。

SPB1 訂購參數

型號	帶吸盤接頭						備件 替換吸盤墊	選購部件 濾網 (孔徑尺寸: 280 μm)
	M5-AG(外)	M5-IG(內)	G1/8-AG(外)	G1/8-IG(內)	G1/4-AG(外)	G1/4-IG(內)		
SPB1-10-...	●	●	-	-	-	-	●	-
SPB1-15-...	-	-	●	●	-	-	●	-
SPB1-20-...	-	-	●	●	-	-	●	●
SPB1-25-...	-	-	●	●	-	-	●	●
SPB1-30-...	-	-	●	●	-	-	●	●
SPB1-40-...	-	-	-	-	●	●	●	●
SPB1-50-...	-	-	-	-	●	●	●	●
SPB1-60-...	-	-	-	-	●	●	●	●
SPB1-80-...	-	-	-	-	●	●	●	●



SPB1 結構參數

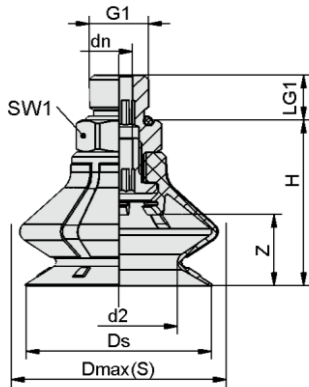

SPB1-...-AG

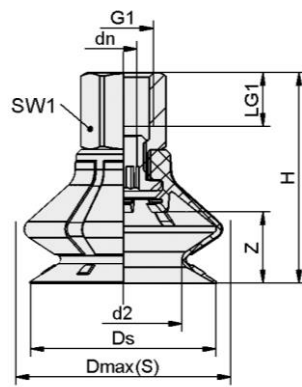

SPB1-...-IG

型號	尺寸[mm] ⁽³⁾									重量 [g]
	dn	d2	Dmax(S)	Ds	G1	H	LG1	SW1	Z(行程)	
SPB1-10-ED-65-M5-AG	1.8	5.6	11.3	9.8	M5-M	17.0	4.7	8	4	2
SPB1-10-ED-65-M5-IG	3.1	5.6	11.3	9.8	M5-F	22.0	5.5	8	4	2
SPB1-15-ED-65-G1/8-AG	4.0	9.5	19.7	15.4	G1/8-M	21.0	7.5	14	6	5
SPB1-15-ED-65-G1/8-IG	4.0	9.5	19.7	15.4	G1/8-F	29.0	8.0	14	6	6
SPB1-20-ED-65-G1/8-AG	4.0	13.8	26.3	21.4	G1/8-M	24.0	7.5	14	8	6
SPB1-20-ED-65-G1/8-IG	4.0	13.8	26.3	21.4	G1/8-F	32.0	8.0	14	8	7
SPB1-25-ED-65-G1/8-AG	4.0	16.9	31.3	26.4	G1/8-M	27.0	7.5	14	11	7
SPB1-25-ED-65-G1/8-IG	4.0	16.9	31.3	26.4	G1/8-F	35.0	8.0	14	11	8
SPB1-30-ED-65-G1/8-AG	4.0	20.0	36.7	31.4	G1/8-M	29.0	7.5	14	13	8
SPB1-30-ED-65-G1/8-IG	4.0	20.0	36.7	31.4	G1/8-F	37.0	8.0	14	13	9
SPB1-40-ED-65-G1/4-AG	6.1	26.1	48.0	41.4	G1/4-M	37.2	10.0	17	16	21
SPB1-40-ED-65-G1/4-IG	6.1	26.1	48.0	41.4	G1/4-F	47.2	12.0	17	16	22
SPB1-50-ED-65-G1/4-AG	6.1	32.3	58.4	51.4	G1/4-M	39.2	10.0	17	18	26
SPB1-50-ED-65-G1/4-IG	6.1	32.3	58.4	51.4	G1/4-F	49.2	12.0	17	18	27
SPB1-60-ED-65-G1/4-AG	6.1	38.6	69.6	61.4	G1/4-M	43.2	10.0	17	22	33
SPB1-60-ED-65-G1/4-IG	6.1	38.6	69.6	61.4	G1/4-F	53.2	12.0	17	22	34
SPB1-80-ED-65-G1/4-AG	6.1	56.0	88.0	81.4	G1/4-M	56.0	10.0	22	24	74
SPB1-80-ED-65-G1/4-IG	6.1	56.0	88.0	81.4	G1/4-F	64.0	12.0	22	24	78

(3)符合 DIN ISO 3302-1 M3 橡膠件允許尺寸公差。



SPB1 結構參數

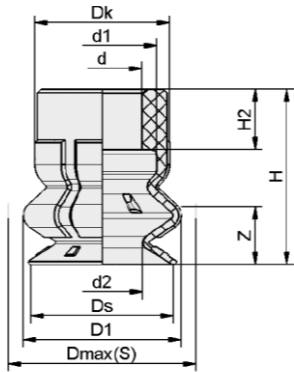

SPB1-10 至 15

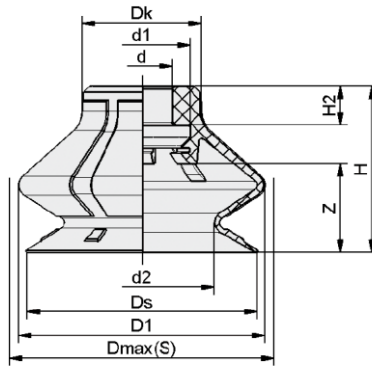

SPB1-20 至 80

型號	尺寸[mm] ⁽³⁾										重量 [g]
	d	d1	d2	D1	Dk	Dmax(S)	Ds	H	H2	Z(行程)	
SPB1-10-ED-65	5.5	7.5	5.6	11.0	9.4	11.3	9.8	12	4.2	4	1
SPB1-15-ED-65	7.5	10.5	9.5	18.4	15.1	19.7	15.4	15	4.6	6	1
SPB1-20-ED-65	7.5	10.5	13.8	24.6	15.1	26.3	21.4	18	4.6	8	2
SPB1-25-ED-65	7.5	10.5	16.9	29.0	15.1	31.3	26.4	21	4.6	11	3
SPB1-30-ED-65	7.5	10.5	20.0	34.2	15.1	36.7	31.4	23	4.6	13	4
SPB1-40-ED-65	11.0	17.5	26.1	44.6	21.6	48.0	41.4	30	7.0	16	8
SPB1-50-ED-65	11.0	17.5	32.3	55.2	21.6	58.4	51.4	32	7.0	18	13
SPB1-60-ED-65	11.0	17.5	38.6	65.7	21.6	69.6	61.4	36	7.0	22	20
SPB1-80-ED-65	14.0	29.3	56.0	82.7	27.1	88.0	81.4	46	15.3	24	40

(4)符合 DIN ISO 3302-1 M3 橡膠件允許尺寸公差。